

KITCHEN ARCHITECTURE
VOL. II

STORIA HISTORY

In 1958 Giovanni and Francesco Bolletta, two young joiners, created the Binova brand in Assisi, Umbria, the green heart of Italy, and started a company that has made and still is making the history of high quality kitchens. Ever since, Binova has been leading the important journey of the Italian kitchen production, exploring all the potential of wood and analyzing the material science and technology. A real cultural and technological challenge that this company faces with an imposing production line, always heading to new materials, thanks to their in-house Research and Development department that continuously creates new important and revolutionary combinations and design patents. All these years and experience allowed Binova to express an extraordinary talent for the choice of materials, their processing and whole kitchen furniture production. Some of the most prestigious architects and designers are Binova's precious partners, to guarantee an elegant and contemporary charm with special care for ergonomics and functionality: the key that makes out of Binova's creations the most incredible laboratories for taste and pleasure. In 2018 the brand became part of the Cubo Design group, led by Antonio Arangiaro. This passage has been a real multidirectional booster for the company: a stronger passion for product research and development and the project of a brand new enlarged production plant, with the most advanced equipment to guarantee the constant quality and control of the whole production line, that will be completely in-house. Binova is an ambassador of the Italian design in the World: severe and elegant, but also definitely glamorous and fascinating, enduring through the years.



2

3



La storia di Binova nasce nel 1958 con Giovanni e Francesco Bolletta che, da giovanissimi falegnami di bottega ad Assisi, sono cresciuti nella passione e nell'arte della lavorazione del legno creando Binova, l'azienda umbra che ha fatto scuola nel mondo delle cucine di alta qualità. Da allora, Binova esprime ancora al meglio l'impegno della produzione di ambienti cucina, esplorando le potenzialità del legno, della scienza dei materiali e della meccanica. Una sfida culturale e tecnologica, affrontata con impegnativi processi produttivi spinti sempre verso nuovi materiali, grazie a un centro di ricerca e sviluppo interno all'azienda che ha prodotto importanti e rivoluzionari invenzioni e brevetti. Anni di ricerca e crescita progettuale hanno portato Binova ad esprimere una cura straordinaria nella scelta dei materiali, nella lavorazione e nei sistemi di produzione dei mobili. Architetti e designer di prestigio, preziosi collaboratori, garantiscono il gusto per una contemporaneità ricercata e allo stesso tempo ergonomica e funzionale che fa delle cucine e degli ambienti Binova degli autentici laboratori del gusto e del piacere. Nel 2018 il passaggio al gruppo Cubo Design, fondato da Antonio Arangiaro, ha aggiunto una nuova forza propulsiva multidirezionale: nuovi investimenti, una rinnovata passione per la ricerca e lo sviluppo dei prodotti, il progetto di un grande stabilimento all'avanguardia, in cui verrà riunita tutta la filiera produttiva, per garantire massimo controllo e qualità costante dell'intero processo produttivo. Binova è un emblema del design italiano in tutto il mondo: rigorosamente elegante, mostra tutto il suo fascino solido e inalterabile senza timore del tempo.

INNOVAZIONE 4.0 INNOVATION 4.0



4

5

Il 2018 ha il sapore di un vero e proprio passo epocale per Cubo Design. Viene attuata una riorganizzazione radicale dei suoi asset principali, attraverso un'interpretazione del futuro ispirata ad efficienza, efficacia e rispetto dell'ambiente, che nel nuovo polo di 25.000 m² trovano concretezza grazie a soluzioni tecniche, informatiche ed energetiche, totalmente integrate: nasce Factory-One. Una struttura avveniristica, in cui la produzione di cucine viene affrontata e risolta con sistemi intelligenti, attraverso l'integrazione totale tra processi e controllo umano. Un percorso con andamento lineare e non più ad isole di lavoro, costituito da macchinari altamente tecnologici, interconnessi e contraddistinti da assoluta precisione, costantemente garantita mediante il controllo effettuato da manodopera specializzata. Appositi sensori che sfruttano il collegamento alla rete, permettono di monitorare le varie fasi della lavorazione industriale e di conoscere in tempo reale lo status delle apparecchiature su cui sono collegati. Un sistema d'eccellenza, in cui il concetto di industry 4.0 viene implementato in modo completo, divenendo propulsore del business di Cubo Design. 2018 has the flavor of a real epochal step for Cubo Design. A radical reorganization of its main assets is implemented, through an interpretation of the future inspired by efficiency, effectiveness and respect for the environment, which in the new pole of 25.000 m² are concretized thanks to fully integrated technical, IT and energy solutions: Factory-One is born. A futuristic structure, in which the production of kitchens is addressed and resolved with intelligent systems, through the total integration between processes and human control. A route with a linear progress and no longer with work islands, made up of highly technological machinery, interconnected and characterized by absolute precision, constantly guaranteed through the control carried out by skilled labor. Special sensors that exploit the connection to the network, allow you to monitor the various stages of industrial processing and to know in real time the status of the equipment on which they are connected. A system of excellence, in which the concept of industry 4.0 is fully implemented, becoming the driving force behind Cubo Design's business.

PREMIAZIONI AWARDS



6

7

1973 / CENTRAL BLOCK Design Barzotti T.

1985 / OPERA Design Castiglia Associati

1993 / PRIMA

Selected in 2011 By Abitare magazine: "The long river of the italian design 1961-2011". Design Paolo Nava

1994 / HWRS

Binova patents the flushed built-in Design Paolo Nava

2001 / REGULA

Selected for the Compasso d'Oro Adi 2001 and by I.Dot for the (Italian design on tour). Design Paolo Nava and Fabio Casiraghi

2002 / STAZIONE DI LAVORO LAB

Selected for the Compasso d'Oro Adi 2002
Design Paolo Nava and Fabio Casiraghi

2003 / SISTEMA INDEX

Selected for the Compasso d'Oro Adi 2003
Design Paolo Nava and Fabio Casiraghi

2003 / 2004 / FIRES LINE

Selected for the Compasso d'Oro Adi 2003 and 2004
Design Paolo Nava and Fabio Casiraghi

2011 / MCS MULTI COOKING SYSTEM

Selected for the "Wallpaper Design Awards 2011"
Design Paolo Nava and Fabio Casiraghi

COLLEZIONI COLLECTIONS



REGULA + BLUNA

32
53



10
31

SCAVA + BLUNA



54
77

BLUNA METAL 4.0



MANTIS + BLUNA

100
121



BLUNA + VOGUE

122
143



VOGUE + BLUNA

166
187



188
209

BLUNA + LAB



BLUNA TECH

210
231

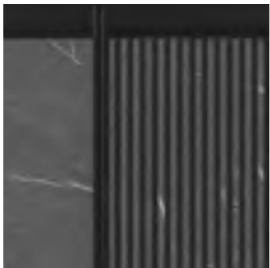

78
99

AVOLA



144
165

BLUNA LEGNO

10

11

SCAVA + BLUNA



SCAVA + BLUNA

QUANDO LA SOTTRAZIONE DIVENTA FUNZIONE.

13

Mostrare ciò che altri celano lascia più spazio all'immaginazione di quanto si creda. Il progetto Scava di fatti è caratterizzato da frontali che hanno una presa sulla parte superiore e che grazie ad un piano di lavoro inscritto all'interno delle strutture ne consente l'apertura. Una ricerca multi-direzionale che sposta continuamente il fuoco del movimento, che ora corre in piano e un attimo dopo sale lungo gli elementi verticali in legno che vanno da terra a cielo. L'ambiente è caratterizzato da due grandi spazi delimitati al centro da tre pilastri in legno con funzione dispensa e contenimento degli elettrodomestici ad incasso. La prima area è una cucina con due zone di lavoro, un'isola centrale ed una parete attrezzata, mentre la seconda offre un ampio spazio living con tavolo, madie e divano. Un ambiente da esplorare senza filtri, con la sensazione di vivere in una completa interazione tra persona e spazio. Showing what the others hide means leaving space for imagination. Scava project is characterized by fronts that have a grip on the upper part and which thanks to a worktop built at the same depth of structures allows the opening. A multidirectional research that constantly changes its target, following a smooth top and climbing along three wooden pillars from floor to ceiling. The environment is characterized by two large areas delimited in the center by three wooden pillars with a pantry function and space for built-in appliances. The first area is a kitchen with two work areas, a central island and an equipped wall, while the second offers a large living space with table, sideboards and sofa. An environment to explore without filters, with the feeling of living in a complete interaction between person and space.

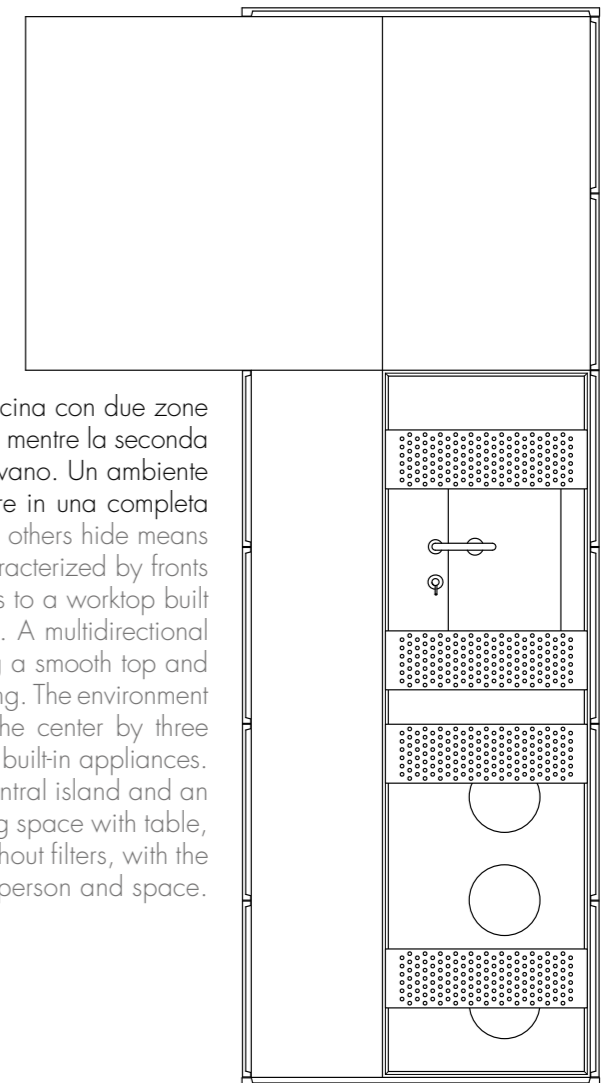





16



17

DETTAGLIO COLONNA CANTINA CON ANTE REFLEX IN VETRO FUME' E TELAIO IN FINITURA ALLUMINIO NERO. STRUTTURA INTERNA IN BILAMINATO LEGNO ROVERE FUME' CON SCHIENA IN FINITURA GREY FABRIC.

DETAIL OF WINE CELLAR COLUMN WITH REFLEX DOORS MADE IN FUME' GLASS AND BLACK ALUMINIUM FRAME. INTERNAL STRUCTURE IS IN WOOD BILAMINATE ROVERE FUME' FINISH AND BACK PANEL IS IN GREY FABRIC FINISH.

DETAIL COLONNE CAVA A VIN AVEC PORTE REFLEX EN VERRE FUME ET CADRE EN FINITION ALUMINIUM NOIR. STRUCTURE INTERNE EN BILAMINE BOIS ROVERE FUME AVEC DOS EN FINITION GREY FABRIC.

DETALLE DE LA CAVA DE VINO CON PUERTAS REFLEX EN VIDRIO AHUMADO Y MARCO EN ACABADO DE ALUMINIO NEGRO. ESTRUCTURA INTERNA EN BILAMINADO DE MADERA ROVERE FUME' CON ESPALDA EN ACABADO GREY FABRIC.





DETTAGLIO PILASTRI H
235,5 CM IN FINITURA
BILAMINATO LEGNO
ROVERE FUME' CON
MODULI A GIORNO
OPEN IN FINITURA
LACCATO OPACO NERO
TRAFFICO.

DETAIL OF PILLARS
H 235,5 CM IN WOOD
BILAMINATE ROVERE
FUME' FINISH WITH
OPEN SPACE UNITS
MATT LACQUERED
NERO TRAFFICO
FINISH.

DETAIL PILIERS H
235,5 CM EN FINITION
BILAMINE BOIS
ROVERE FUME AVEC
MEUBLES OUVERTS
OPEN EN FINITION
LAQUE MAT NERO
TRAFFICO.

DETALLE DE PILARES
H 235.5 CM EN
BILAMINADO DE MADERA
ACABADO ROVERE
FUME' CON MÓDULOS
ABIERTOS LACADO MATE
EN ACABADO NEGRO
TRÁFICO.





22

23



DETTAGLIO ANTA
SCAVA IN LACCATO
METAL 4.0 FORESTA
E WORKTOP DUNA
IN GRES INSIDE
FINITURA PIETRA
PIASENTINA TAUPE
FIAMMATA.

DETAIL OF SCAVA
DOOR 4.0 METAL
LACQUERED FORESTA
FINISH AND DUNA
WORKTOP INSIDE
GRES PIETRA
PIASENTINA TAUPE
FIAMMATA FINISH.

DETAIL FAÇADE SCAVA
EN FINITION LAQUE
METAL 4.0 VERDE
FORESTA ET PLAN DE
TRAVAIL DUNA EN
GRES INSIDE FINITION
PIETRA PIASENTINA
TAUPE FIAMMATA.

DETALLE PUERTA
SCAVA EN LACA
OXIDADA VERDE
FORESTA Y ENCIMERA
DUNA GRES INSIDE
ACABADO EN PIEDRA
PIASENTINA TAUPE
LLAMA.

DETTAGLIO MADIA
ALTA IN LACCATO
METAL 4.0 FORESTA
E LEGNO EUCALIPTO
SCURO. BASAMENTO
VERNICIATO NERO
OPACO.

DETAIL OF SIDEBOARD
4.0 METAL LACQUERED
FORESTA FINISH AND
WOOD EUCALIPTO
SCURO FINISH. LOWER
STRUCTURE MATT
BLACK LACQUERED.

DETAIL BUFFET
HAUT LAQUE
METAL 4.0 VERDE
FORESTA ET BOIS
EUCALIPTO SCURO.
BASE VERNIE NOIR
MAT.

DETALLE APARADOR
ALTO EN LACA
OXIDADA VERDE
FORESTA Y MADERA
EUCALIPTO SCURO.
BASE PINTADA NEGRA
MATE.

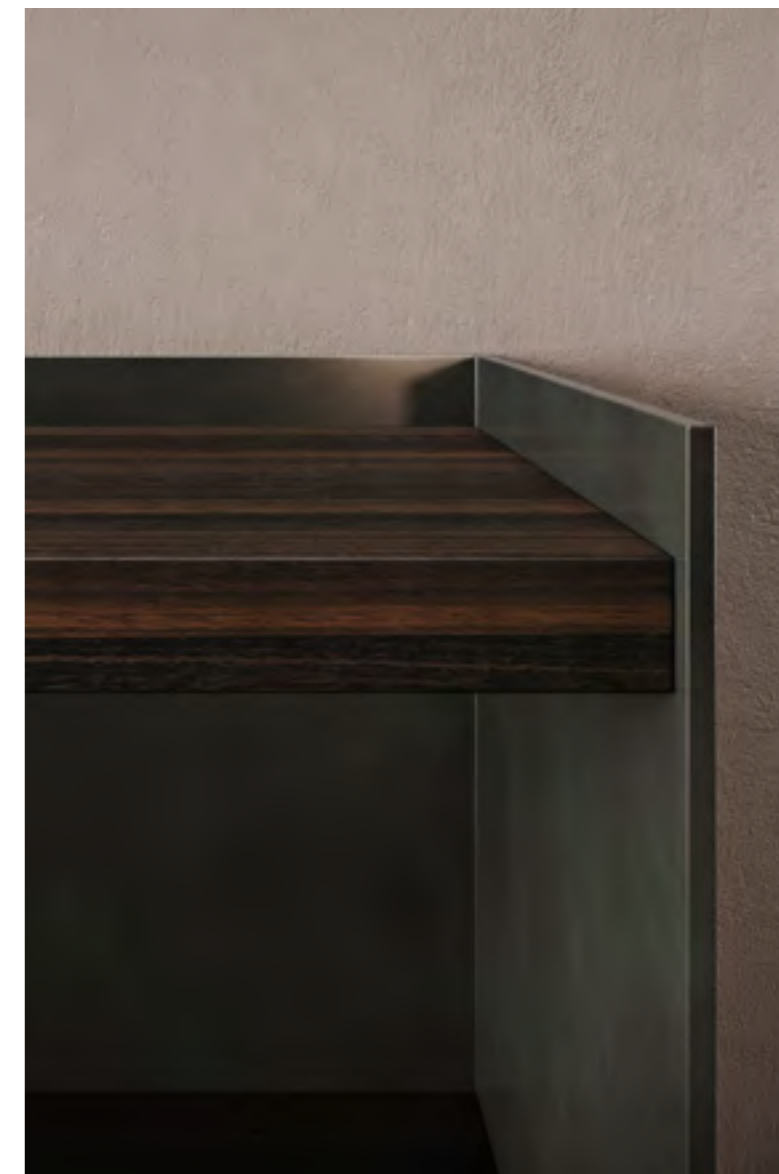





DETTAGLIO PARETE LIVING CON ANTE IN FINITURA BILAMINATO LEGNO ROVERE FUME' E SCHIENALI IN FINITURA TECH ALLUMINIO BRUNITO.

DETAIL OF LIVING WALL MADE IN WOOD BILAMINATE ROVERE FUME' DOORS AND BACK PANELS IN TECH ALLUMINIO BRUNITO FINISH.

DETAIL MUR LIVING AVEC FAÇADES EN FINITION BILAMINE BOIS ROVERE FUME ET DOS FINITION TECH ALUMINIUM BRUNI.

DETALLE DE PARED LIVING CON PUERTAS BILAMINADO DE MADERA ACABADO ROVERE FUME' Y ESPALDA ACABADO TECH EN ALUMINIO BRUNITO.



1
COLONNE PIASTRATI PILLAR COLUMNS COLONNES PILIER COLUMNAS PILAR
 BLUNA BILAMINATO LEGNO ROVERE FUME' CON MODULI A GIORNO OPEN LACCATO OPACO NERO TRAFFICO E ROVERE FUME'. STRUTTURA INTERNA GREY FABRIC

2
ISOLA ISLAND ÎLOT ISLA
 SCAVA LACCATO METAL 4.0 FORESTA, WORKTOP DUNA GRES INSIDE PIETRA PIASENTINA TAUPE FIAMMATO CON TEGOLE IN ACCIAIO SPAZZOLATO, PIANO SNACK MOVE DIAGONAL LEGNO EUCALIPTO SCURO. STRUTTURA INTERNA GREY FABRIC

3
PENSILI WALL UNITS MEUBLES HAUT MUEBLES ALTOS
 OFFSET BILAMINATO LEGNO IN FINITURA ROVERE FUME' E STRUTTURA INTERNA IN FINITURA GREY FABRIC

4
COLONNE COLUMNS COLONNES COLUMNAS
 BLUNA BILAMINATO LEGNO FINITURA ROVERE FUME' CON MANIGLIA TRACCIA NERO. STRUTTURA INTERNA IN FINITURA GREY FABRIC

5
COLONNE VETRINA GLASS COLUMNS COLONNES VITRINES COLUMNAS VETRINA
 REFLEX VETRO FUME' E TELAIO FINITURA ALLUMINIO NERO. STRUTTURA INTERNA IN BILAMINATO LEGNO ROVERE FUME' CON SCHIENA GREY FABRIC. RIPIANI LED PORTABOTTIGLIE IN ALLUMINIO VETRO E VETRO FUME'

6
MADIE SIDEBOARDS BUFFETS PATILLAS
 BLUNA LACCATO METAL 4.0 FORESTA E LEGNO SPECIALE EUCALIPTO SCURO. STRUTTURA IN NERO CARBONE E BASAMENTO IN METALLO NERO OPACO

7
TAVOLO TABLE TABLE MESA
 PISA STRUTTURA IN LEGNO ROVERE CARBONE E PIANO IN GRES INSIDE PIETRA PIASENTINA TAUPE FIAMMATO

8
SOGGIORNO LIVING WALL MUR DE SÉJOUR MURO DE SALÒN
 AVOLA LEGNO SPECIALE EUCALIPTO SCURO CON TELAIO NERO, BOISERIE LEAF BILAMINATO LEGNO ROVERE FUME' CON MENSOLE LACCATO OPACO NERO TRAFFICO, PIANO IN GRES INSIDE PIETRA PIASENTINA TAUPE FIAMMATO, SCHIENALI IN TECH ALLUMINIO BRUNITO. STRUTTURA IN NERO CARBONE

30

SCAVA + BLUNA

SCHEDA TECNICA DATA SHEET
FICHE TECHNIQUE FICHA DE DATOS

31

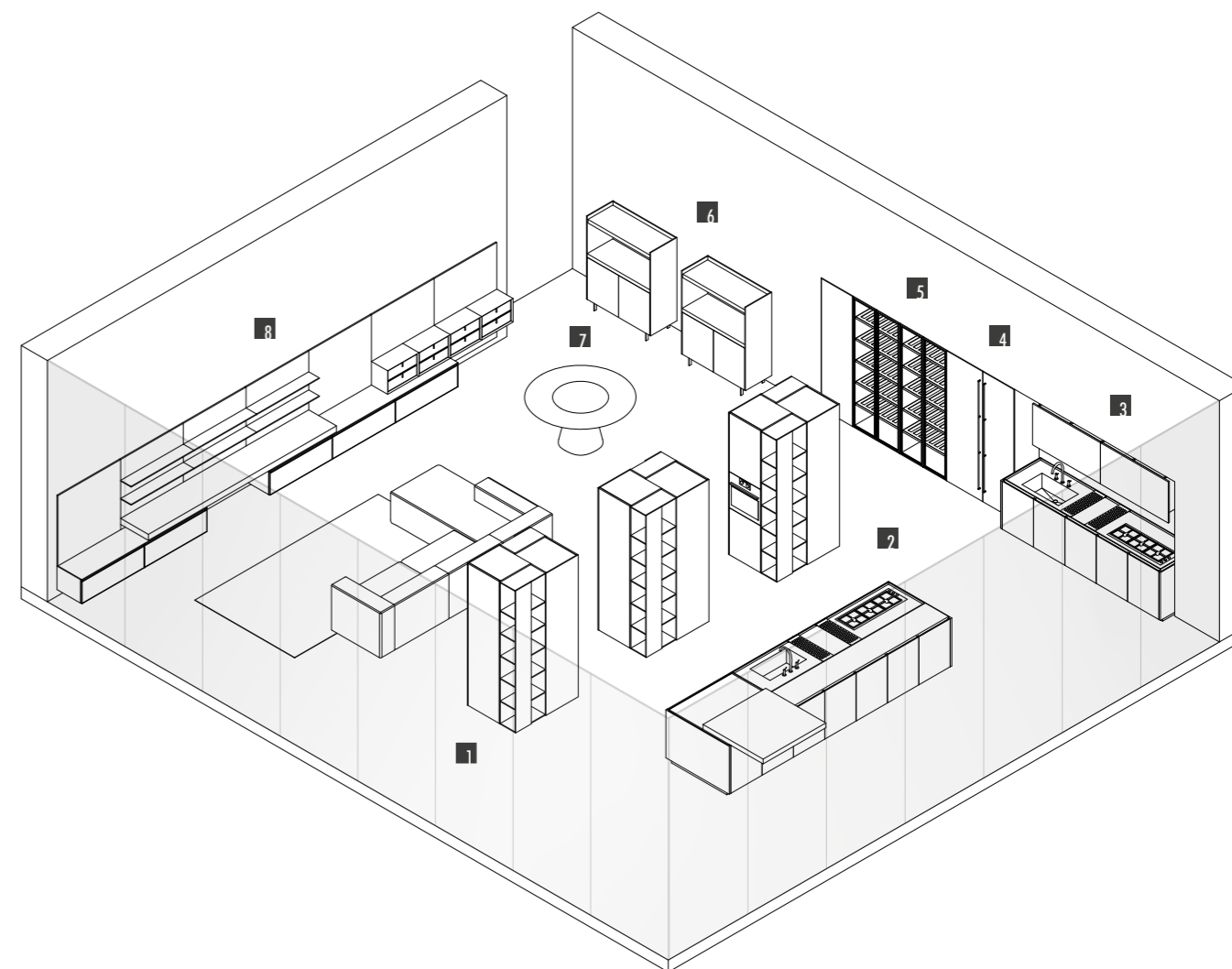

32

33

REGULA + BLUNA



REGULA + BLUNA

QUANDO LA CUCINA È IN PIEDI.

35

Osare sempre un po' di più. L'audacia di cambiare può custodire il seme di quella genialità che fa intuire la direzione prima di altri, dell'attimo in cui si capisce di aver realizzato qualcosa che si credeva impossibile. Umanamente si cresce e si allungano le distanze tra un'orma e l'altra. Così Regula, nata nel 1998, non ha mai cessato di crescere, fino a portare avanti ancora oggi il suo concetto di leggerezza estrema. Un ambiente che ruota attorno a due isole sospese su piedini, entrambe caratterizzate da un monoblocco centrale in gres Nero greco che interrompe il piano di lavoro generando rispettivamente un'area con lavello integrato in gres ed un'area con piano cottura. Fanno da sfondo una parete di colonne vetro Reflex illuminate con led verticali ed interrotte nella parte centrale da quattro colonne in Fenix Rosso Jaipur contenenti forni e frigorifero. Tutt'attorno si sviluppano un'area living con divano ed un'area pranzo con tavolo e madia alta. Boldness of changing can be the shell of the genius pearl. As humans grow up, the distance between their footsteps becomes wider. The same happens to Regula, born in 1998, until today it continues its concept of extreme lightness. An ambient composed by two islands suspended on feet, both characterized by a central block made in Nero greco gres that divide the worktop, respectively generating an area with an integrated sink and an area with a cooktop. The background is a wall of Reflex glass columns illuminated with vertical LEDs and interrupted in the central part by four columns in Fenix Rosso Jaipur containing ovens and refrigerator. All around there is a living area with sofa and another area with table and glass sideboard.

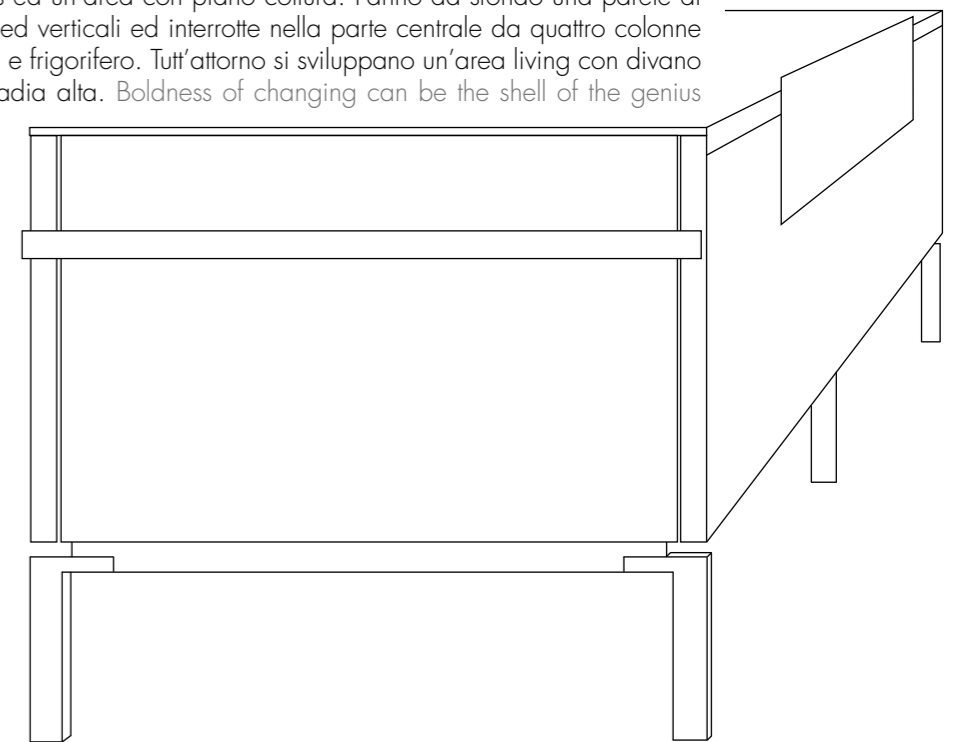





38

39



DETTAGLIO
MONOBLOCCO LAVELLO
IN FINITURA GRES
NERO GRECO OPACO E
ANTE BLUNA LEGNO
IN FINITURA ROVERE
VESUVIO DOGA
SFALSATA.

DETAIL OF SINK
MONOBLOCK IN MATT
GRES NERO GRECO
FINISH AND DOORS IN
BLUNA WOOD VENEER
ROVERE VESUVIO
DOGA SFALSATA
FINISH.

DETAIL MONOBLOC
EVIER EN FINITION
GRES NOIR MAT ET
FAÇADES BLUNA
BOIS EN FINITION
ROVERE VESUSIO
AVEC LATTES
IRREGULIERES.

DETALLE FREGADERO
MONOBLOCCO EN
ACABADO GRES
NERO GRECO MATE Y
PUERTAS DE MADERA
ACABADO ROVERE
VESUVIO LISTON
ESCALONADO.





DETTAGLIO FIANCHI
ESTERNI E PIEDINO
ISOLA REGULA IN
ALLUMINIO NERO
OPACO.

DETAIL OF SIDE
PANELS AND REGULA
FOOT MADE IN
ALUMINIUM MATT
BLACK FINISH.

DETAIL COTES
EXTERNES ET
PIEDS ILOT EN
ALUMINIUM NOIR
MAT.

DETALLE COSTADOS
LATERAL EXTERIORES
Y PATAS ISLA REGULA
EN ALUMINIO NEGRO
MATE.





44



45

DETTAGLIO COLONNE
VETRINA CON ANTE
REFLEX IN VETRO
FUME' E TELAIO IN
FINITURA ALLUMINIO
NERO. STRUTTURA
INTERNA IN FINITURA
BILAMINATO ROVERE
TERRANERA CON
SCHIENA IN FINITURA
NERO CARBONE.

DETAIL OF GLASS
COLUMNS WITH
REFLEX DOORS MADE
IN FUME' GLASS AND
BLACK ALUMINUM
FRAME. INTERNAL
STRUCTURE IS IN
BILAMINATE ROVERE
TERRANERA AND BACK
PANEL IS IN NERO
CARBONE FINISH.

DETAIL COLONNES
VITRINES AVEC PORTE
REFLEX EN VERRE
FUME ET CADRE EN
FINITION ALUMINIUM
NOIR. STRUCTURE
INTERNE EN FINITION
BILAMINE ROVERE
TERRANERA AVEC DOS
EN FINITION NERO
CARBONE.

DETALLES COLUMNAS
VETRINA CON PUERTAS
REFLEX EN VIDRIO FUME'
Y MARCO EN ACABADO
DE ALUMINIO NEGRO.
ESTRUCTURA INTERNA
EN BILAMINADO DE
MADERA ACABADO
ROVERE TERRANERA CON
ESPALDA EN ACABADO
NERO CARBONE.

DETTAGLIO MADIE ALTE CON ANTE REFLEX IN FINITURA VETRO FUME' E TELAIO IN FINITURA ALLUMINIO NERO. STRUTTURA INTERNA IN BILAMINATO ROVERE TERRANERA CON SCHIENA NERO CARBONE.

DETAIL SIDEBOARDS WITH REFLEX DOORS MADE IN FUME' GLASS AND BLACK ALUMINUM FRAME. INTERNAL STRUCTURE IS IN BILAMINATE ROVERE TERRANERA FINISH AND BACK PANEL IS IN NERO CARBONE FINISH.

DETAIL BUFFET HAUT AVEC PORTE REFLEX EN VERRE FUME ET CADRE EN FINITION ALUMINIUM NOIR. STRUCTURE INTERNE EN FINITION BILAMINE ROVERE TERRANERA AVEC DOS EN FINITION NERO CARBONE.

DETALLES APARADOR ALTO CON PUERTAS REFLEX EN VIDRIO FUME' Y MARCO EN ACABADO DE ALUMINIO NEGRO. ESTRUCTURA INTERNA EN BILAMINADO DE MADERA ACABADO ROVERE TERRANERA CON ESPALDA EN ACABADO NERO CARBONE.







DETTAGLIO PARETE LIVING CON BASI IN FENIX ROSSO JAIPUR, PIANO IN LEGNO ROVERE CARBONE, BOISERIE IN BILAMINATO LEGNO ROVERE TERRANERA E PANNELLI SCHIENALI IN BILAMINATO MATERICO PIETRA PIASENTINA.

DETAIL OF LIVING WALL WITH LOWER BASES IN ROSSO JAIPUR, FENIX, TOP IN ROVERE CARBONE WOOD, BOISERIE IN ROVERE TERRANERA WOOD BILAMINATE AND BACK PANELS IN MATERICO BILAMINATE PIETRA PIASENTINA.

DETAIL MUR LIVING AVEC MEUBLES BAS EN FENIX ROSSO JAIPUR, PLAN EN BOIS ROVERE CARBONE, BOISERIE EN BILAMINE BOIS ROVERE TERRANERA ET PANNEAUX DOS EN BILAMINE PIETRA PIASENTINA.

DETALLE DE PARED LIVING CON BAJOS EN FENIX ROSSO JAIPUR, SUPERFICIE DE MADERA EN ROVERE CARBONE, BOISERIE EN BILAMINADO DE MADERA ACABADO ROVERE TERRANERA Y PANELES DE ESPALDA EN BILAMINADO MATERICO PIETRA PIASENTINA.

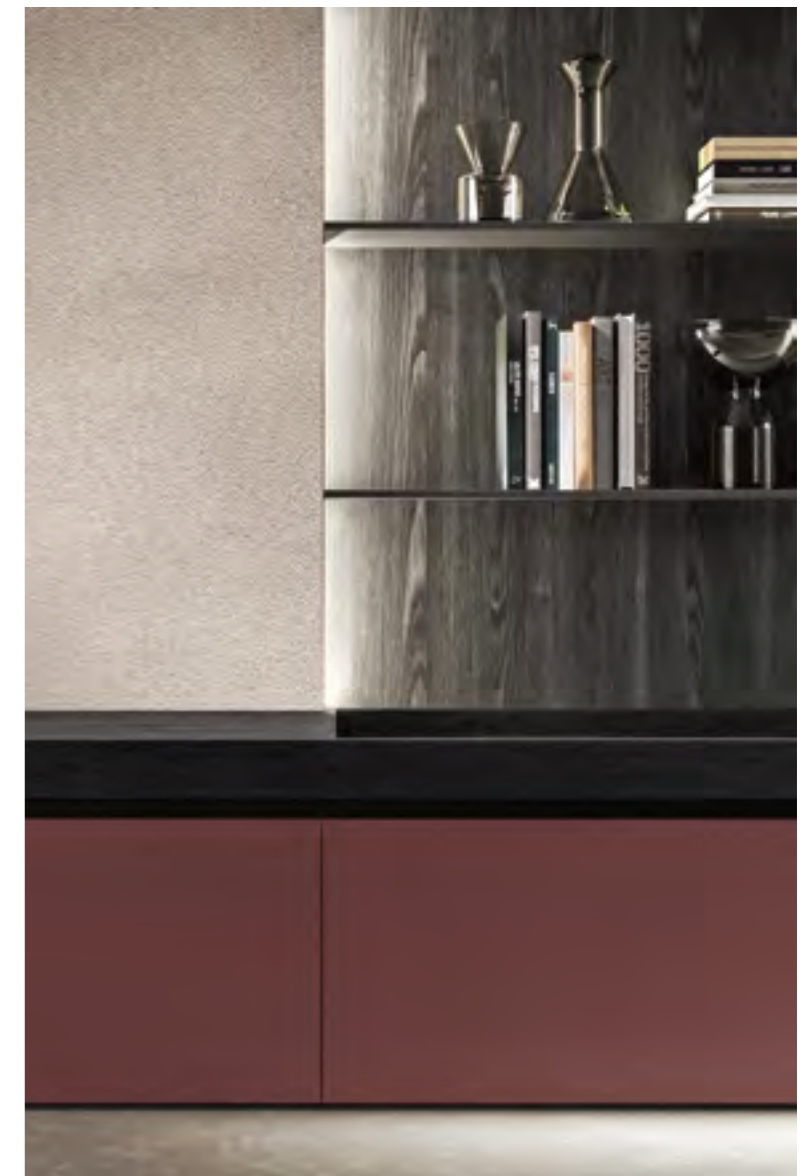

1

COLONNE COLUMNS COLONNES COLUMNAS

BLUNA LAMINATO FENIX ROSSO JAIPUR CON APERTURA PUSH-PULL. STRUTTURA INTERNA IN FINITURA NERO CARBONE

2

COLONNE VETRINA GLASS COLUMNS COLONNES VITRINES COLUMNAS VETRINA

REFLEX VETRO FUMÉ E TELAIO FINITURA ALLUMINIO NERO. STRUTTURA INTERNA IN BILAMINATO LEGNO ROVERE TERRANERA CON SCHIENA NERO CARBONE. RIPIANI IN VETRO FUMÉ

3

ISOLE ISLANDS ÎLOTS ISLAS

REGULA CON STRUTTURA ALLUMINIO NERO OPACO E ANTE BLUNA LEGNO SPECIALE ROVERE VESUVIO DOGA SFALSATA. WORKTOP GRES NERO GRECO OPACO. STRUTTURA INTERNA IN FINITURA NERO CARBONE

4

MADIE SIDEBOARDS BUFFETS PATILLAS

REGULA CON STRUTTURA ALLUMINIO NERO OPACO, ANTE REFLEX VETRO FUMÉ E TELAIO FINITURA ALLUMINIO NERO. STRUTTURA INTERNA IN BILAMINATO LEGNO ROVERE TERRANERA CON SCHIENA NERO CARBONE. RIPIANI IN VETRO FUMÉ

5

TAVOLO TABLE TABLE MESA

AFFIORO STRUTTURA IN LEGNO ROVERE CARBONE E PIANO IN GRES FINITURA NERO GRECO OPACO

6

SOGGIORNO LIVING WALL MUR DE SÉJOUR MURO DE SALÒN

BLUNA LAMINATO FENIX ROSSO JAIPUR, BOISERIE LEAF BILAMINATO LEGNO ROVERE TERRANERA CON MENSOLE LACCATO OPACO NERO TRAFFICO, PIANO IN LEGNO ROVERE CARBONE, SCHIENALI IN BILAMINATO MATERICO PIETRA PIASENTINA. STRUTTURA INTERNA IN FINITURA NERO CARBONE



LAMINATO FENIX ROSSO JAIPUR



LEGNO SPECIALE ROVERE VESUVIO DOGA SFALSATA

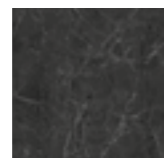

GRES NERO GRECO OPACO



BILAMINATO LEGNO ROVERE TERRANERA

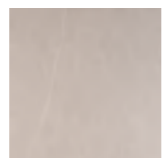

BILAMINATO MATERICO PIETRA PIASENTINA



LEGNO ROVERE CARBONE



BILAMINATO STRUTTURA NERO CARBONE



VETRO FUMÉ E ALLUMINIO NERO

52

REGULA + BLUNA

**SCHEDA TECNICA DATA SHEET
FICHE TECHNIQUE FICHA DE DATOS**

53

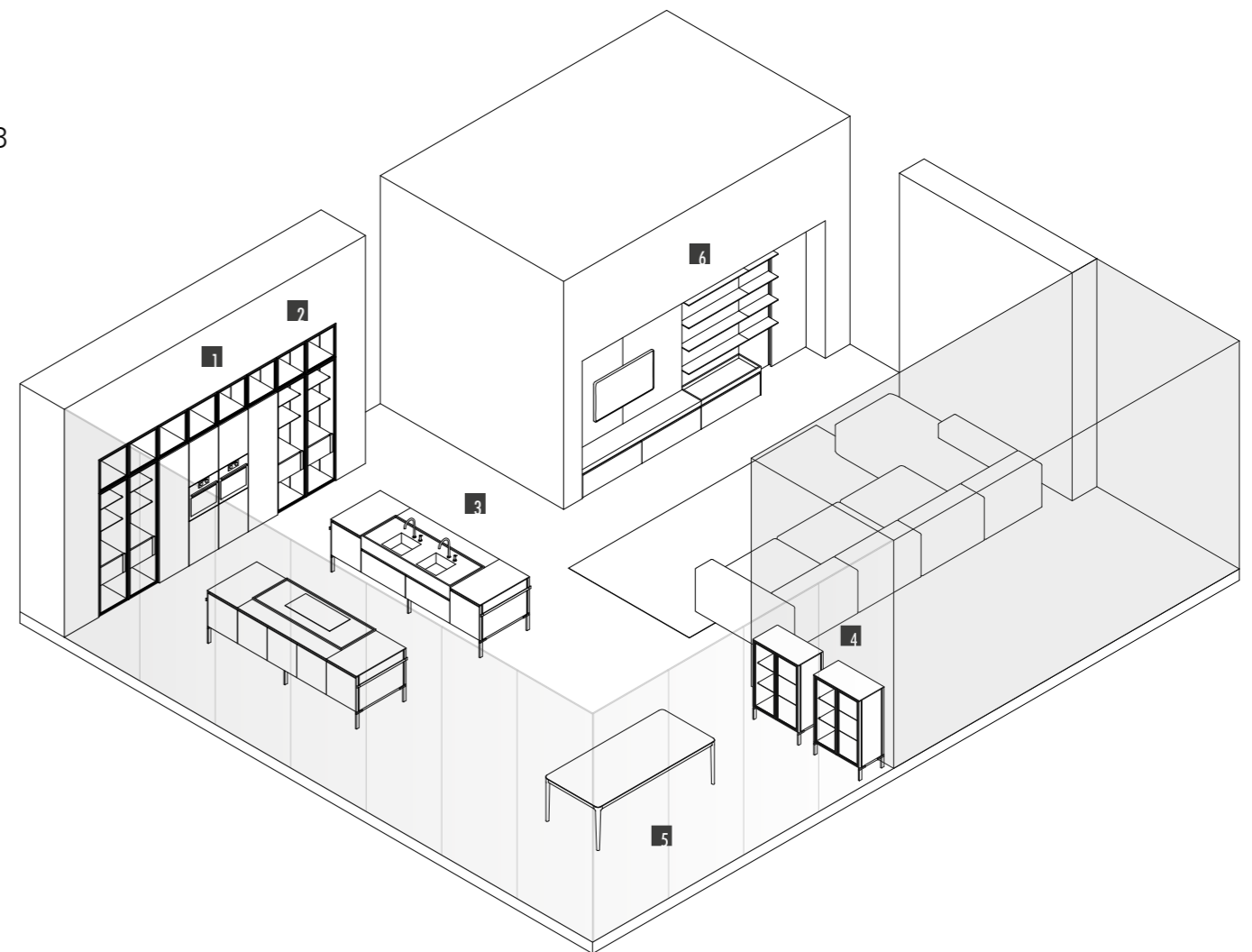

54

55

BLUNA METAL 4.0



BLUNA METAL 4.0

DOVE UNA SPIGA DIVENTA L'INTERO SISTEMA DI APERTURA.

57

Un ambiente che mette in relazione gli spazi della casa, eliminando la separazione tra zona cucina e soggiorno. Grazie all'uso delle colonne pilastri, elementi verticali contenitivi e funzionali, ogni ambiente si sviluppa in aree delimitate ma aperte, simili a spazi teatrali, di ampio respiro. Due materiali innovativi caratterizzano la composizione: da una parte, il laccato metal 4.0 che riveste le colonne ed esalta la modernità dell'insieme, dall'altra il legno Old abete nero, che costituisce l'isola centrale concepita come un blocco monolitico. Viene recuperato appositamente dai manti esterni di masi e tabià, abitazioni e fienili molto diffusi in Trentino-Alto Adige e in Friuli-Venezia Giulia. Rinasce a nuova vita attraverso operazioni di pulitura e stucco e mediante un'accurata lavorazione artigianale, è unico nel suo genere, in quanto l'aspetto e le caratteristiche nuance che presenta sono state determinate esclusivamente dall'azione congiunta del sole e di agenti atmosferici come neve, pioggia e vento. Altro elemento importante è l'innovativo top Spiga realizzato in Gres. L'inclinazione a 30° delle ante e il top generano un piacevole interstizio; lo spazio in luce che ricorda la caratteristica forma a V della spiga di grano, accresce il concetto di una nuova estetica funzionale dando accesso agli spazi attrezzati. An entire ambient that connects spaces in the home, removing the distinction between kitchen and living space. By using the pillat columns, vertical functional and storage units, each space is open yet enclosed, similar to wide open theatrical space. Two innovative materials characterize the composition: on the one hand, the 4.0 metal lacquer that covers the columns and enhances the modernity of the whole, on the other the Old black fir wood, which constitutes the central island conceived as a monolithic block. It is specially recovered from the external coats of farms and tabiàs, homes and barns very common in Trentino-Alto Adige and Friuli-Venezia Giulia. It is reborn to new life through cleaning and stucco operations and through careful craftsmanship, it is unique in that its appearance and the nuances it presents have been determined exclusively by the joint action of the sun and atmospheric agents such as snow, rain and wind. Another important element is the innovative Spiga worktop made in Gres material. The inclination of 30° doors and the top create a nice gap, the space in the shade enhances the concept of a new functional aesthetics where shadow cones give access to spaces equipped and operational.

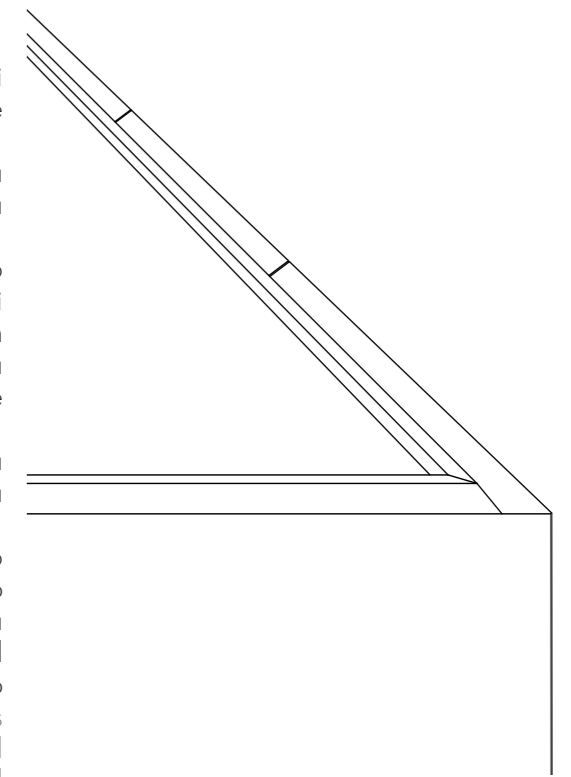





60



61

DETTAGLIO ISOLA CON ANTE BLUNA PROFILO 30° IN FINITURA LEGNO PREMIUM OLD ABETE NERO. TOP SPIGA IN GRES OPACO FINITURA MARBLE GREY.

ISLAND DETAIL OF BLUNA DOORS WITH 30° PROFILE IN PREMIUM WOOD OLD ABETE NERO FINISH. SPIGA WORKTOP IN MATT GRES MARBLE GREY FINISH.

DÉTAIL ILOT AVEC FAÇADES BLUNA PROFIL 30° FINITION BOIS PREMIUM OLD ABETE NERO. PLAN DE TRAVAIL EN GRÈS MAT FINITION MARBLE GREY.

DETALLE ISLA CON PUERTAS BLUNA PERFIL DE 30 ° EN MADERA ACABADO PREMIUM OLD ABETE NERO. ENCIMERA SPIGA EN GRES MATE ACABADO MARBLE GREY.





DETTAGLIO COLONNE
PILASTRI IN FINITURA
BLUNA LACCATO
METAL 4.0 BRONZO
E LACCATO OPACO
NERO TRAFFICO,
MODULI A GIORNO
CLOSE IN FINITURA
LACCATO OPACO NERO
TRAFFICO.

DETAIL OF PILLAR
COLUMNS IN BLUNA
OZIDIZED LACQUERED
BRONZE FINISH AND
MATT LACQUERED
NERO TRAFFICO
FINISH, OPEN SPACE
UNIT "CLOSE" MATT
LACQUERED NERO
TRAFFICO FINISH.

DETAIL COLONNE
PILIERS EN FINITION
BLUNA LAQUE
METAL 4.0 BRONZE
ET LAQUE MAT
NERO TRAFFICO,
MEUBLES OUVERTS
CLOSE EN FINITION
LAQUE MAT NERO
TRAFFICO.

DETALLE COLUMNAS
PILARES EN BLUNA
ACABADO LACADO
METAL 4.0 BRONZO
LACADO MATE
NEGRO TRÁFICO,
MÓDULOS ABIERTOS
Y CLOSE EN LACADO
ACABADO MATE
NEGRO.





66

67



DETTAGLIO COLONNE
CON ANTE MILES
IN VETRO FUME' E
TELAIO IN FINITURA
ALLUMINIO NERO.
STRUTTURA INTERNA
IN FINITURA
BILAMINATO ROVERE
TERRANERA CON
SCHIENA IN FINITURA
GREY FABRIC.

DETAIL OF COLUMNS
WITH MILES DOORS
MADE IN FUME'
GLASS AND BLACK
ALUMINUM FRAME.
INTERNAL STRUCTURE
IS IN WOOD
BILAMINATE ROVERE
TERRANERA AND
BACK PANEL IS IN
GREY FABRIC FINISH.

DETAIL COLONNES
AVEC FAÇADES
MILES EN VERRE
FUME ET CADRE EN
FINITION ALUMINIUM
NOIR. STRUCTURE
INTERNE EN FINITION
BILAMINE ROVERE
TERRANERA AVEC DOS
EN FINITION GREY
FABRIC.

DETALLES DE COLUMNAS
CON PUERTAS MILES
EN VIDRIO FUME' Y
MARCO EN ACABADO
DE ALUMINIO NEGRO.
ESTRUCTURA INTERNA
EN BILAMINATO DE
MADERA ACABADO DE
ROVERE TERRANERA
CON ESPALDA EN
ACABADO GREY FABRIC.

DETTAGLIO MADIA
CON ANTE MILES
IN VETRO FUME' E
TELAIO IN FINITURA
ALLUMINIO NERO.
STRUTTURA INTERNA
IN FINITURA
BILAMINATO ROVERE
TERRANERA CON
SCHIENA IN FINITURA
GREY FABRIC. PIANO
IN GRES OPACO
FINITURA MARBLE
GREY.

DETAIL OF
SIDEBOARD WITH
MILES DOORS MADE
IN FUME' GLASS AND
BLACK ALUMINIUM
FRAME. INTERNAL
STRUCTURE IS IN
WOOD BILAMINATE
ROVERE TERRANERA
AND BACK PANEL
IS IN GREY FABRIC
FINISH. PLANE IN
MATT GRES MARBLE
GREY FINISH.

DETAIL BUFFET
AVEC FAÇADES
MILES EN VERRE
FUME ET CADRE EN
FINITION ALUMINIUM
NOIR. STRUCTURE
INTERNE EN FINITION
BILAMINE ROVERE
TERRANERA AVEC DOS
EN FINITION GREY
FABRIC. PLAN DE
TRAVAIL EN GRÈS MAT
FINITION MARBLE
GREY.

DETALLE DEL APARADOR
CON PUERTAS DE
MILLAS HECHAS EN
VIDRIO DE FUMA Y
MARCO DE ALUMINIO
NEGRO. LA ESTRUCTURA
INTERNA ESTÁ EN
MADERA BILAMINADA
ROVERE TERRANERA Y
EL PANEL POSTERIOR
ESTÁ EN ACABADO DE
TELA GRIS. PLANO EN
ACABADO GRIS MÁRMOL
GRIS MATE.







DETTAGLIO PARETE LIVING CON BASI SOSPESE IN FINITURA BLUNA LACCATO METAL 4.0 BRONZO CON PROFILO GAP IN ALLUMINIO NERO, PENSILI CON ANTE VETRO MILES CON TELAIO NERO E VETRO FUMÉ, SCHIENALI IN BILAMINATO LEGNO FINITURA ROVERE TERRANERA.

DETAIL OF LIVING WALL WITH BASE UNITS BLUNA 4.0 METAL LACQUERED BRONZO FINISH WITH BLACK ALUMINUM GAP PROFILE, WALL UNITS WITH MILES GLASS DOORS MADE IN BLACK ALUMINUM FRAME AND FUMÉ GLASS, BACK PANELS ARE IN WOOD BILAMINATE ROVERE TERRANERA FINISH.

DETAIL MUR LIVING AVEC MEUBLES BAS SUSPENDUS EN FINITION BLUNA LAQUE METAL 4.0 BRONZE AVEC PROFIL GAP EN ALUMINIUM NOIR, MEUBLES HAUTS AVEC FAÇADES EN VERRE MILES AVEC CADRE NOIR ET VERRE FUMÉ, DOS EN BILAMINE BOIS FINITION ROVERE TERRANERA.

DETALLE PARED LIVING CON BAJOS SUSPENDIDOS LACADO METAL 4.0 ACABADO BRONZO CON PERFIL GAP EN ALUMINIO NEGRO, ALTOS CON PUERTAS DE VIDRIO MILES CON MARCO DE ALUMINIO NEGRO Y VIDRIO FUMÉ, ESPALDA EN BILAMINADO DE MADERA ACABADO ROVERE TERRANERA.





1 COLONNE COLUMNS COLONNES COLUMNAS

BLUNA LACCATO METAL 4.0 BRONZO E LACCATO OPACO NERO TRAFFICO CON APERTURA GOLA VERTICALE. MODULI A GIORNO CLOSE LACCATO OPACO NERO TRAFFICO. STRUTTURA INTERNA IN FINITURA NERO CARBONE

2 ISOLA ISLAND ÎLOT ISLA

BLUNA CON PROFILO 30° LEGNO PREMIUM OLD ABETE NERO, APERTURA CONSENTITA MEDIANTE WORKTOP SPIGA IN GRES MARBLE GREY OPACO. STRUTTURA INTERNA NERO CARBONE

3 COLONNE VETRINA GLASS COLUMNS COLONNES VITRINES COLUMNAS VETRINA

MILES VETRO FUMÉ E TELAIO FINITURA ALLUMINIO NERO. STRUTTURA INTERNA IN BILAMINATO LEGNO ROVERE TERRANERA CON SCHIENA GREY FABRIC. RIPIANI IN BILAMINATO LEGNO ROVERE TERRANERA CON CARTER ALLUMINIO NERO

4 MADIA SIDEBBOARD BUFFET PATILLA

MILES VETRO FUMÉ E TELAIO FINITURA ALLUMINIO NERO. STRUTTURA INTERNA IN BILAMINATO LEGNO ROVERE TERRANERA CON SCHIENA GREY FABRIC. PIANO IN GRES MARBLE GREY OPACO

5 SOGGIORNO LIVING WALL MUR DE SÉJOUR MURO DE SALÒN

BLUNA LACCATO METAL 4.0 BRONZO CON PROFILO GAP ALLUMINIO NERO, VETRINE MILES VETRO FUMÉ E TELAIO FINITURA ALLUMINIO NERO. STRUTTURA INTERNA IN BILAMINATO LEGNO ROVERE TERRANERA CON SCHIENA GREY FABRIC.

6 TAVOLO TABLE TABLE MESA

MORGAN STRUTTURA IN FINITURA NERO OPACO CON PIANO IN GRES MARBLE GREY OPACO

7 LIBRERIA LIBRARY BIBLIOTHÈQUE BIBLIOTECA

PIVOT STRUTTURA IN FINITURA ALLUMINIO NERO OPACO E RIPIANI IN BILAMINATO LEGNO ROVERE TERRANERA CON CARTER ALLUMINIO NERO

76

77

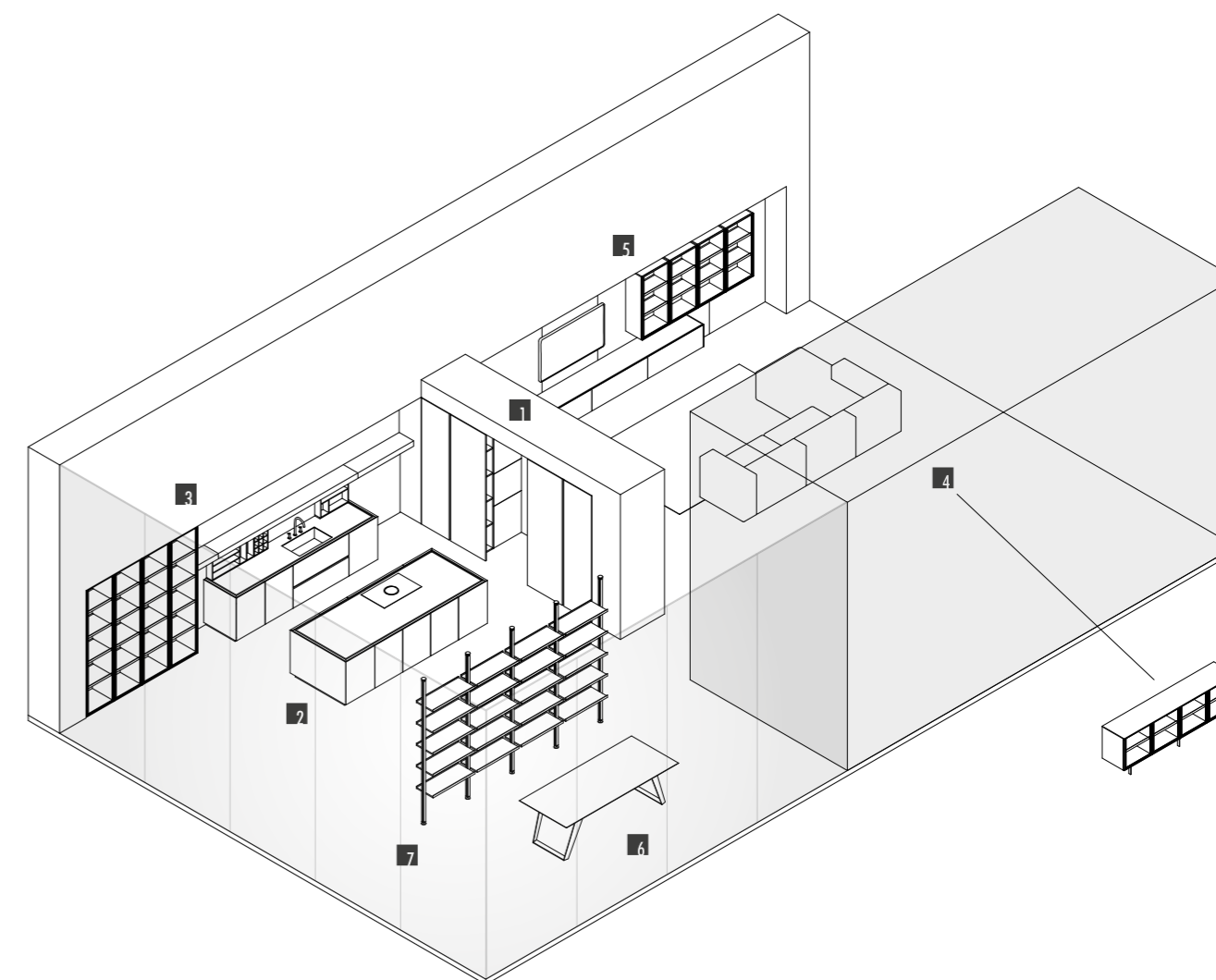

BLUNA METAL 4.0

SCHEDA TECNICA DATA SHEET
FICHE TECHNIQUE FICHA DE DATOS

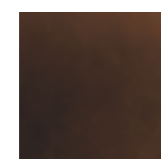

LACCATO METAL
4.0 BRONZO



LEGNO PREMIUM
OLD ABETE NERO



GRES MARBLE GREY
OPACO



BILAMINATO
LEGNO ROVERE
TERRANERA



LACCATO OPACO
NERO TRAFFICO



BILAMINATO
STRUTTURA NERO
CARBONE



VETRO FUMÉ E
ALLUMINIO NERO

78

79

AVOLA



AVOLA

DOVE UN TELAIO PUO' AVERE INFINITE ANIME.

81

Dare libertà è un atto di grande forza. Permettere ai materiali di andare oltre la propria attitudine dimostra la capacità di mettersi a disposizione della natura per amplificarne le possibilità: dalla duttilità innata del legno alle suggestioni stellari. E' un intero universo che si fa completamente tangibile e si presenta in una veste polifunzionale, lasciandoci liberi di sperimentare le profondità di spazio e di materia. Un atto di grande libertà: quella del design minimalista che apre alla percezione di un'essenza marmorea che corre lungo i profili e le venature, segni precisi che diventano traccia comune e viva nel contrasto del chiaroscuro e nell'equilibrio costante tra l'estetica d'insieme e il punto del dettaglio. L'espansione di movimento diventa totale grazie al telaio in alluminio, che accoglie comodamente il pannello centrale ed al contempo consente la presa sulla parte superiore. Allowing freedom is the sign of a great strength. We let materials get over their own attitude. It implies the ability to become a real tool of nature to enhance the range of possibilities of elements like the native mildness of wood or the suggestions coming from outer space. A whole universe comes at hand, tangible and in a multipurpose capacity, allowing us to experience the deepness of space and substance. This is an expression of real liberty: the minimalist design is free to run with its vivid essence along contours and grain, sharp lines that become a common sign, living in the light and shade, balancing the global aesthetics and the slightest particulars. A model that is expansion: thanks to the aluminum frame, which comfortably allow space for the central panel and at the same time allows opening grip on the top edge.

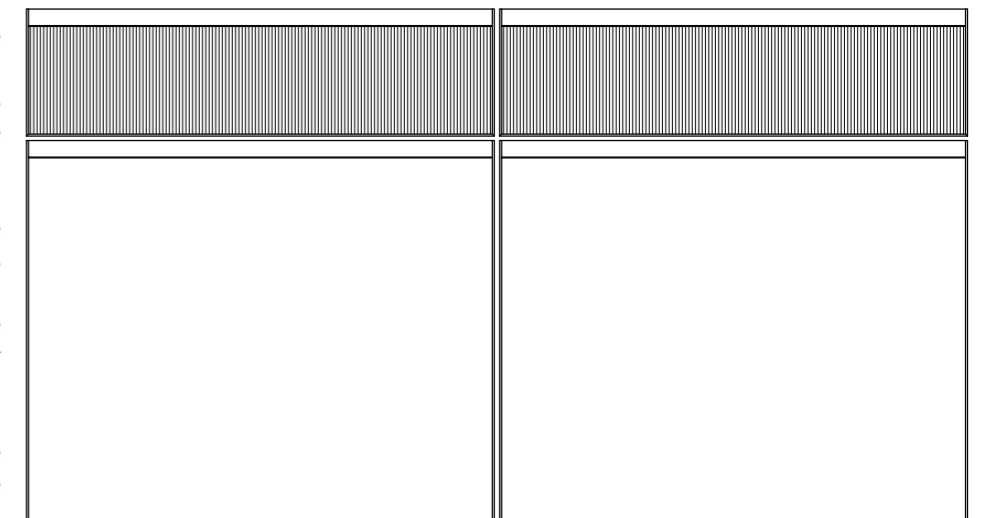





84

85



DETTAGLIO
COLONNA DUE ANTE
RIENTRANTI CON
TELAIO FINITURA
NERO OPACO E LEGNO
IN FINITURA NOCE
CANALETTO CON
LAVORAZIONE RIGATA.

DETAIL OF COLUMN
WITH RETRACTABLE
DOORS IN BLACK
ALUMINUM FRAME
AND WOOD
CANALETTO WALNUT
FINISH WITH RIBBED
CUSTOMIZATION.

DETAIL COLONNE
DEUX PORTES
RENTRANTES AVEC
CADRE EN FINITION
NOIR MAT ET BOIS
EN FINITION NOCE
CANALETTO AVEC
RAYURES.

DETALLE COLUMNA
DE DOS PUERTAS
RENTRANTES CON
MARCO ACABADO NERO
MATE Y ENCHAPADO
DE MADERA ACABADO
NOCE CANALETTO CON
PROCESAMIENTO RAYADO.





DETTAGLIO ANTA
AVOLA CON TELAIO IN
ALLUMINIO NERO E
PANNELLO CENTRALE
IN HPL FINITURA
PIETRA ALICANTE.

DETAIL OF DOOR WITH
BLACK ALUMINUM
FRAME AND CENTRAL
PART IN HPL
ALICANTE STONE
FINISH.

DETAIL FAÇADE AVOLA
AVEC CADRE EN
ALUMINIUM NOIR ET
Panneau central en
HPL FINITION PIETRA
ALICANTE.

DETALLE DE LA PUERTA
AVOLA CON MARCO
DE ALUMINIO NERO
Y PANEL CENTRAL EN
HPL ACABADO PIEDRA
ALICANTE.

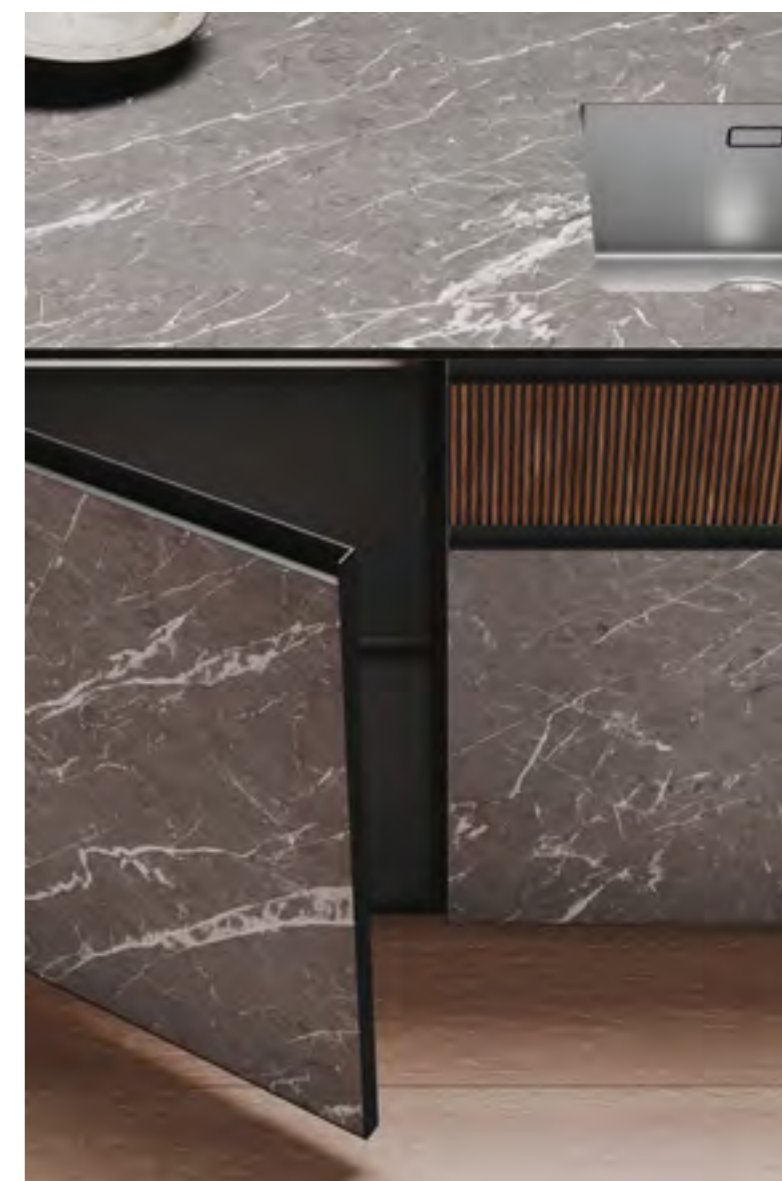



90

91

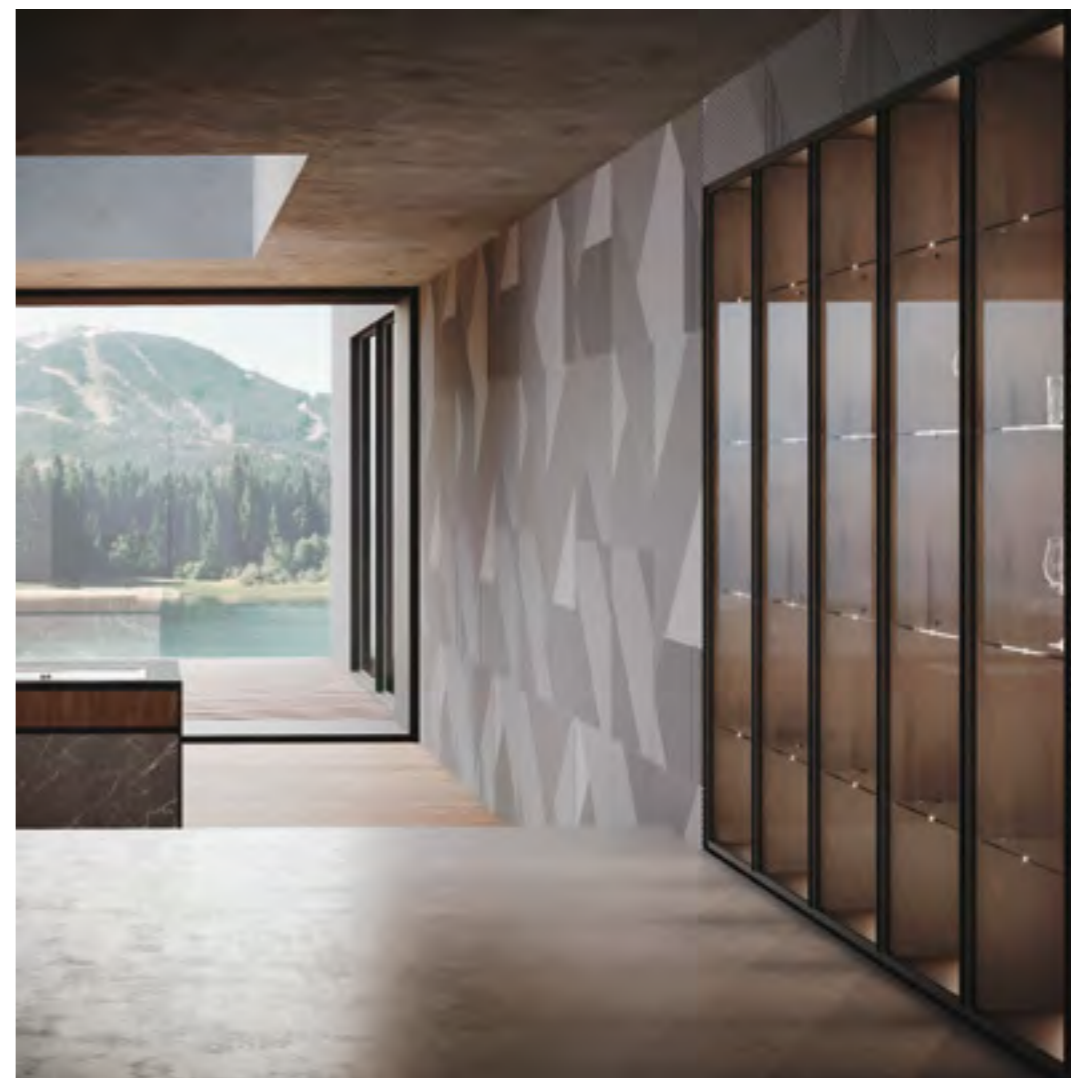

DETTAGLIO COLONNE
CON ANTE REFLEX IN
VETRO FUME' E TELAIO
IN FINITURA ALLUMINIO
NERO OPACO.

DETAIL OF COLUMN
WITH REFLEX DOORS
MADE IN FUME'
GLASS AND BLACK
ALUMINUM FRAME.

DETAIL COLONNE
AVEC PORTES REFLEX
EN VERRE FUME ET
CADRE EN FINITION
ALUMINIUM NOIR MAT.

DETALLES DE COLUMNAS
CON PUERTAS REFLEX
EN VIDRIO FUME' Y
MARCO EN ACABADO DE
ALUMINIO NERO MATE.

DETTAGLIO MADIA
CON ANTE TELAIO IN
ALLUMINIO NERO E
PANNELLO CENTRALE IN
FINITURA GRES INSIDE
PIETRA PIASENTINA
GRIGIA FIAMMATA, TOP
IN FINITURA LEGNO
NOCE CANALETTO.

DETAIL OF SIDEBOARD
WITH BLACK
ALUMINIUM FRAME
DOORS AND CENTRAL
PANEL INSIDE GRES
PIETRA PIASENTINA
FIAMMATA FINISH,
TOP IS IN CANALETTO
WALNUT WOOD.

DETAIL BUFFET AVEC
PORTES AVEC CADRE EN
ALUMINIUM NOIR ET
Panneau central en
finition gres inside
pierre piacentina
grigio fiammata, plan
en finition bois noce
canaletto.

DETALLE APARADOR ALTO
CON PUERTAS DE MARCO
EN ALUMINIO NERO Y
PANEL CENTRAL EN GRES
INSIDE ACABADO PIEDRA
PIASENTINA GRIS LLAMA,
ENCIMERA ENCHAPADO
DE MADERA ACABADO
NOCE CANALETTO.

92

93







DETTAGLIO LIVING
CON ANTE TELAIO
IN FINITURA
ALLUMINIO NERO E
PANNELLO CENTRALE
IN FINITURA GRES
INSIDE PIETRA
PIASENTINA GRIGIA
FIAMMATA, TOP E
PENSILE METRICO IN
FINITURA LEGNO NOCE
CANALETTO, BOISERIE
LEAF IN FINITURA
LACCATO OPACO
GRIGIO ANTRACITE.

DETAIL OF LIVING
AREA WITH BLACK
ALUMINIUM FRAME
DOORS AND CENTRAL
PANEL INSIDE GRES
PIETRA PIASENTINA
FIAMMATA FINISH,
TOP AND METRIC
WALL UNIT IS IN
WOOD CANALETTO
WALNUT FINISH,
BOISERIE LEAF IS IN
MATT LACQUERED
GRIGIO ANTRACITE
FINISH.

DETAIL LIVING
AVEC PORTES AVEC
CADRE EN FINITION
ALUMINIUM NOIR ET
PANNELLO CENTRAL
EN FINITION GRES
INSIDE PIETRA
PIASENTINA GRIGIA
FIAMMATA, PLAN ET
MEUBLE METRIQUE EN
FINITION BOIS NOCE
CANALETTO, BOISERIE
LEAF EN FINITION
LAQUE MAT GRIGIO
ANTRACITE.

DETALLE PARED LIVING
CON PUERTAS DE
MARCO EN ACABADO
ALUMINIO NERO Y
PANEL CENTRAL EN
ACABADO GRES INSIDE
PIEDRA PIASENTINA
GRIS LLAMA ,
ENCIMERA Y MUEBLE
MÉTRICO ENCHAPADO
DE MADERA ACABADO
NOCE CANALETTO,
BOISERIE LEAF LACA
MATE ACABADO GRIGIO
ANTRACITE.

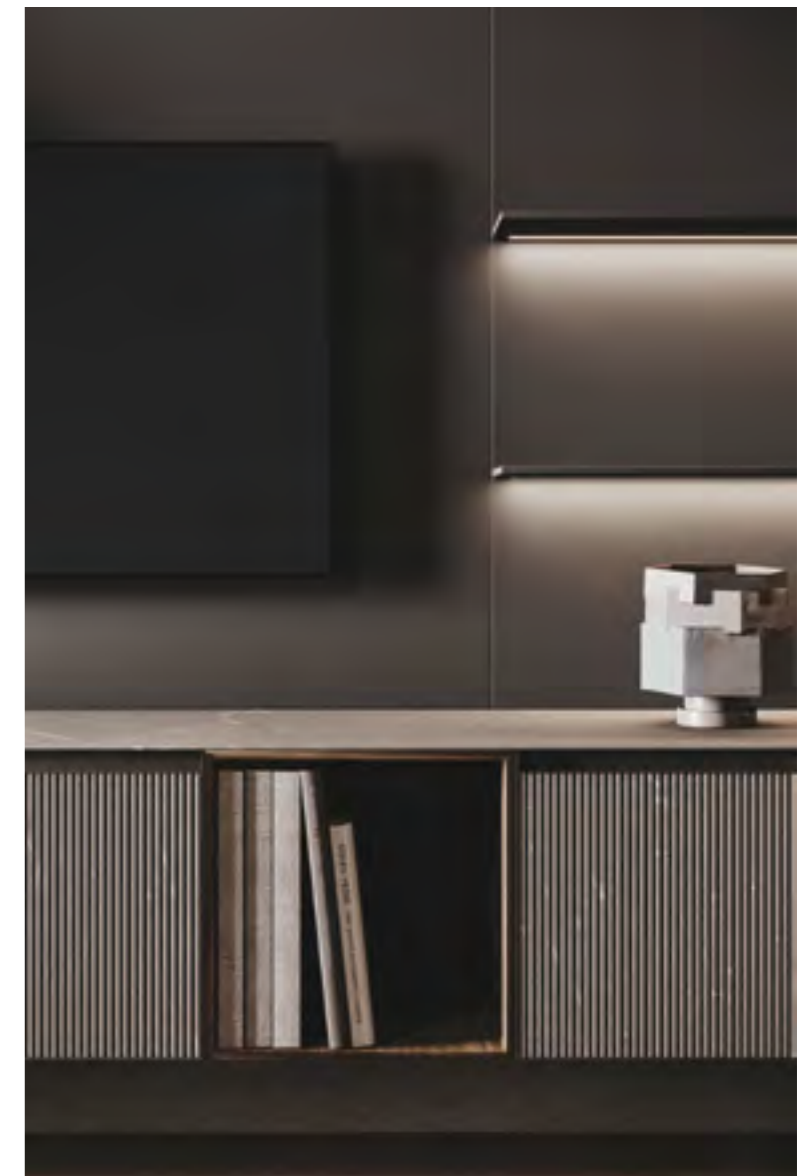

1 COLONNE COLUMNS COLONNES COLUMNAS

AVOLA LEGNO SPECIALE NOCE CANALETTO RIGATO, APERTURA CON MANIGLIA INTEGRATA NELL'ANTA E GOLA VERTICALE, TELAIO ALLUMINIO NERO OPACO. STRUTTURA INTERNA IN FINITURA NERO CARBONE

2 ISOLA ISLAND ÎLOT ISLA

AVOLA LAMINATO HPL ALICANTE E LEGNO SPECIALE NOCE CANALETTO RIGATO, APERTURA CON MANIGLIA INTEGRATA NELL'ANTA, TELAIO ALLUMINIO NERO OPACO. WORKTOP LAMINATO COMPACT ALICANTE. STRUTTURA INTERNA IN NERO CARBONE

3 COLONNE VETRINA GLASS COLUMNS COLONNES VITRINES COLUMNAS VETRINA

REFLEX VETRO FUMÉ E TELAIO FINITURA ALLUMINIO NERO. STRUTTURA INTERNA IN BILAMINATO LEGNO ROVERE FUMÉ CON SCHIENA GREY FABRIC. RIPIANI IN VETRO FUMÉ

4 MADIA SIDEBBOARD BUFFET PATILLA

AVOLA GRES PIETRA PIASENTINA GRIGIO FIAMMATO RIGATO, APERTURA CON MANIGLIA INTEGRATA NELL'ANTA, TELAIO ALLUMINIO NERO OPACO. PIANO E FIANCHI IN LEGNO SPECIALE NOCE CANALETTO. STRUTTURA INTERNA IN FINITURA NERO CARBONE

5 TAVOLO TABLE TABLE MESA

AFFIORO STRUTTURA IN LEGNO NOCE CANALETTO E PIANO IN GRES INSIDE FINITURA PIETRA PIASENTINA GRIGIO FIAMMATO

6 SOGGIORNO LIVING WALL MUR DE SÉJOUR MURO DE SALÒN

AVOLA GRES PIETRA PIASENTINA GRIGIO FIAMMATO RIGATO, PENSILE METRICO E PIANI BLUNA LEGNO SPECIALE NOCE CANALETTO, BOISERIE LEAF LACCATO OPACO NERO TRAFFICO CON MENSOLE LED. STRUTTURA INTERNA IN NERO CARBONE

98

AVOLA

SCHEDA TECNICA DATA SHEET
FICHE TECHNIQUE FICHA DE DATOS

99

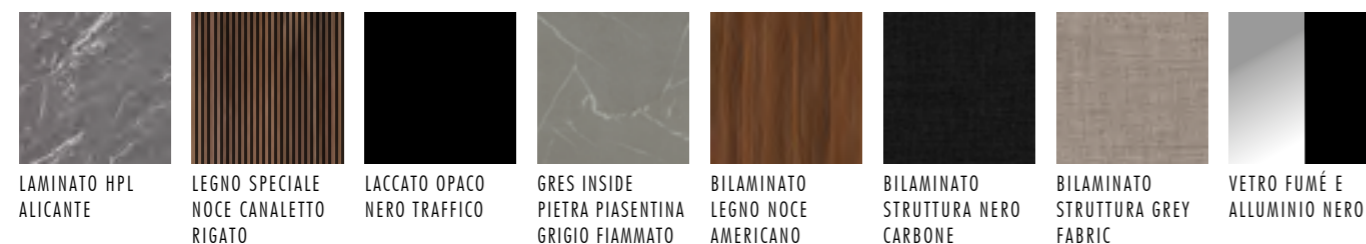
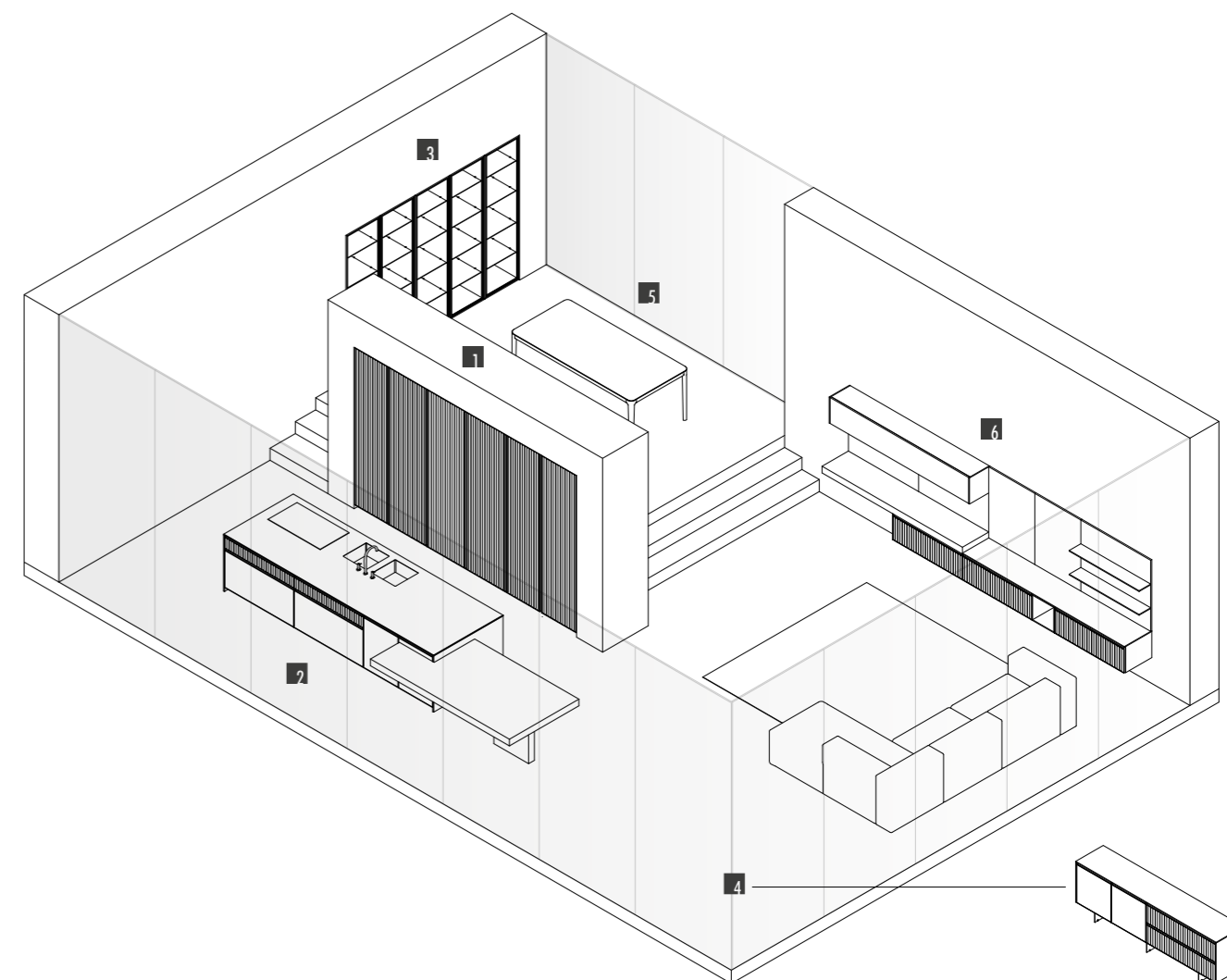

100

101

MANTIS + BLUNA



MANTIS + BLUNA

DOVE SUPERARE I LIMITI DIVENTA POSSIBILE.

103

Andare oltre la possibilità di uno spazio così come ci è dato non è privilegio: è talento. Scomporre lo sguardo significa creare pareti per tracciare uno spazio di vita che sia unico eppure quotidiano. Significa concepire un sistema di linee pure talmente personale in cui riconoscersi da ogni punto di vista. Mantis è un progetto di architettura integrata che porta ai massimi livelli l'evoluzione di tecnologia e spazio, laddove quest'ultimo è espanso in termini di uso e di tempo. L'unione di concetti polari è una cifra costante che si proietta sulla leggerezza degli altissimi frontali resa possibile da ante in alluminio di spessore 12 millimetri realizzate in alveolare di alluminio e rivestite con differenti materiali. Mantis è il momento in cui il progetto si sostituisce all'elemento architettonico, in cui gli elementi che una volta separavano ora creano un continuum: la continuità degli ambienti diventa logica, mentre l'espressione della tecnologia arriva persino ad alleggerire il metallo, rendendo l'insieme degli elementi più raffinato e al contempo più forte e persistente. Improving the resources of a given space is not a chance: it is a real talent. Syllabizing the glance means creating new walls that mark a unique space made out of the essence of our daily life. It is the concept of a whole living system expressed with such pure and universal lines, so personal that it will clearly tell something about us anywhere our gaze will turn. Mantis is an incorporated architecture project representing the evolution of technology and space concepts, as space itself is an extension of time and using capability. The union of polar concepts is the key to read the tall frontals we have created thanks to the 12 millimetre thick aluminium doors. Mantis is a design, taking place of the architectural elements: what once used to separate now is a connection, and the continuity of the spaces becomes a logic consequence. We enhance all the many possibilities that advanced technology delivers, like lightening the strong metal frame to obtain a thinner and persistent product.





106

107



DETTAGLIO TOP
SLIDE FINITURA GRES
TAJ MAHAL OPACO
E ANTA LACCATO
LUCIDO BEIGE KENIA
CON PROFILO 30°.
COLONNE MANTIS IN
FINITURA ROVERE
MAGMA.

DETAIL OF SLIDE GRES
WORKTOP TAJ MAHAL
GLOSSY FINISH AND
GLOSSY LACQUERED
DOOR BEIGE KENIA
FINISH WITH 30°
PROFILE. MANTIS
COLUMNS ROVERE
MAGMA FINISH.

DETAIL PLAN SLIDE
FINITION GRES TAJ
MAHAL MAT ET PORTE
LAQUEE BRILLANT
BEIGE KENIA AVEC
PROFIL 30°. COLONNES
AVEC PORTE MANTIS
EN FINITION ROVERE
MAGMA.

DETALLE ENCIMERA
DESLIZANTE GRES
ACABADO TAJ MAHAL
MATE Y PUERTA LACADA
BRILLANTE BEIGE KENIA
CON PERFIL DE 30°.
COLUMNAS MANTIS EN
ACABADO DE ROVERE
MAGMA.





DETTAGLIO ISOLE
CON PIANO DI
LAVORO SLIDE E
VASCA INTEGRATA IN
FINITURA GRES TAJ
MAHAL OPACO.

DETAIL OF ISLANDS
WITH SLIDE
WORKTOP AND
INTEGRATED SINK
IN MATT GRES TAJ
MAHAL FINISH.

DETAIL ILOT AVEC
PLAN DE TRAVAIL
SLIDE ET VASQUE
INTEGREE EN
FINITION GRES TAJ
MAHAL MAT.

DETALLE DE ISLAS
CON SUPERFICIE DE
TRABAJO SLIDE Y
FREGADERO INTEGRADO
EN GRES ACABADO TAJ
MAHAL MATE.





112

113

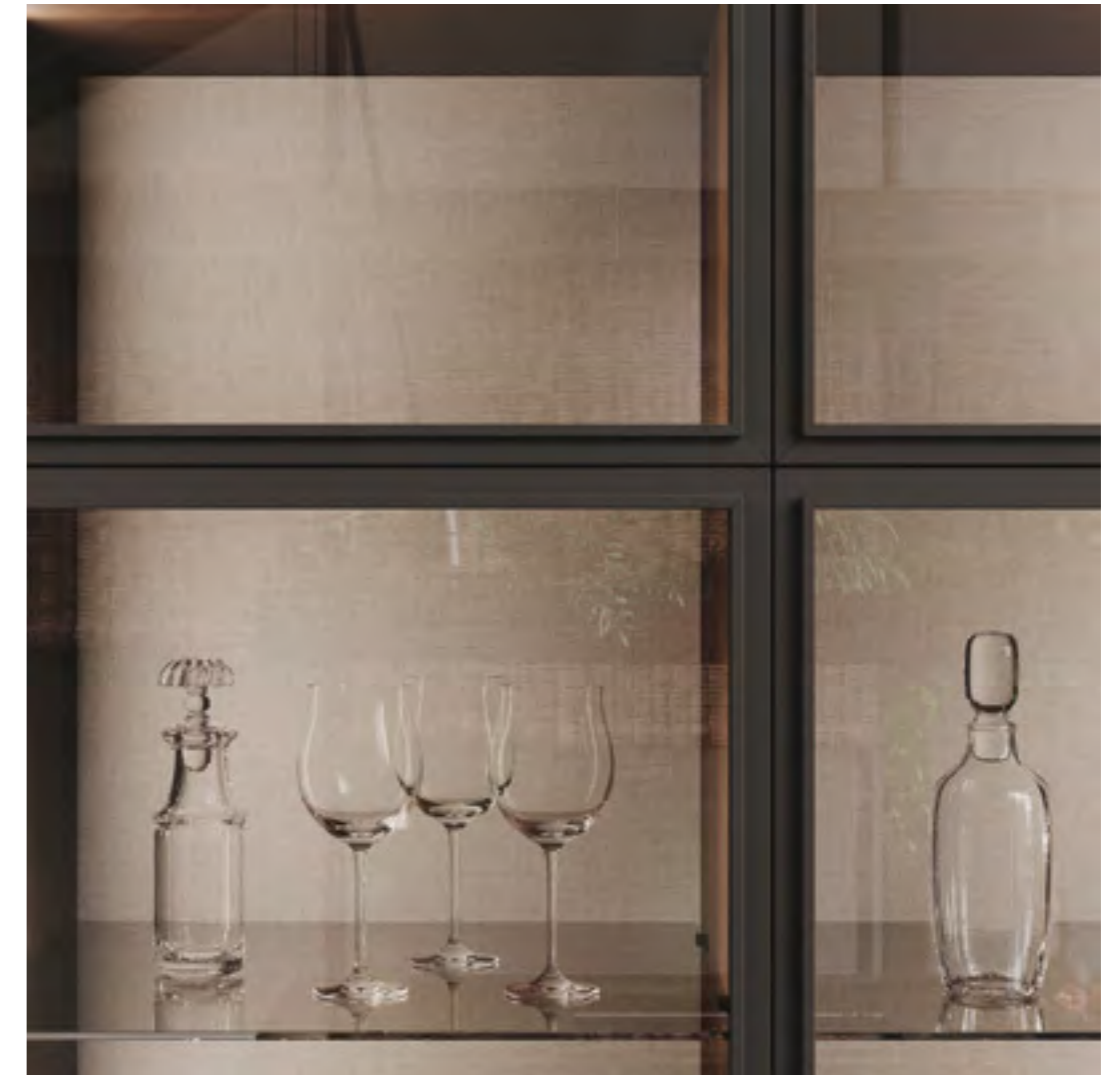

DETTAGLIO COLONNE
CON ANTE REFLEX
IN VETRO FUME' E
TELAIO IN FINITURA
ALLUMINIO NERO.
STRUTTURA INTERNA
IN FINITURA
BILAMINATO ROVERE
FUME' CON SCHIENA
IN FINITURA GREY
FABRIC.

DETAIL OF COLUMNS
WITH REFLEX
DOORS MADE IN
FUME' GLASS AND
BLACK ALUMINUM
FRAME. INTERNAL
STRUCTURE IS IN
WOOD BILAMINATE
ROVERE FUME' AND
BACK PANEL IS IN
GREY FABRIC FINISH.

DETAIL COLONNES
AVEC PORTES
REFLEX EN VERRE
FUME ET CADRE EN
FINITION ALUMINIUM
NOIR. STRUCTURE
INTERNE EN FINITION
BILAMINE ROVERE
FUME AVEC DOS
EN FINITION GREY
FABRIC.

DETALLES DE COLUMNAS
CON PUERTAS REFLEX
EN VIDRIO FUME' Y
MARCO EN ACABADO DE
ALUMINIO NERO MATE.
ESTRUCTURA INTERNA
EN BILAMINADO DE
MADERA ACABADO
ROVERE FUME' CON
ESPALDA EN ACABADO
GREY FABRIC.

DETTAGLIO MADIA
IN FINITURA
LACCATO LUCIDO
BEIGE KENIA ED
INSERTO IN FINITURA
LEGNO ROVERE
TERMOTRATTATO.
BASAMENTO VERNICIATO
NERO OPACO.

DETAIL OF SIDEBOARDS
IN GLOSSY LACQUERED
BEIGE KENIA FINISH
AND INSERT IN
OAK WOOD ROVERE
TERMOTRATTATO
FINISH. LOWER
STRUCTURE MATT
BLACK FINISH.

DETAIL BUFFET EN
FINITION LAQUE
BRILLANT BEIGE
KENIA ET INSERTS
EN FINITION
BOIS ROVERE
TERMOTRATTATO,
BASE VERNIE EN
FINITION NOIR MAT.

DETALLE APARADOR
EN LACADO BRILLANTE
ACABADO BEIGE
KENIA E INSERTE
EN ENCHAPADO DE
MADERA ROVERE
TERMOTRATADO.
BASE PINTADA NEGRA
MATE.

114



115







DETTAGLIO LIVING
CON ANTE MANTIS IN
FINITURA LACCATO
OPACO BEIGE KENIA,
PIANO IN GRES
TAJ MAHAL OPACO
E SCHIENALE IN
BILAMINATO LEGNO
ROVERE TERRANERA.

DETAIL OF LIVING AREA
WITH MANTIS DOORS
MATT LACQUERED
BEIGE KENIA, TOP IN
MATT GRES TAJ MAHAL
FINISH AND BACK
PANEL IN BILAMINATE
WOOD ROVERE
TERRANERA FINISH.

DETAIL LIVING AVEC
PORTES MANTIS EN
FINITION LAQUE MAT
BEIGE KENIA, PLAN
EN GRES TAJ MAHAL
MAT ET DOS EN
FINITION BILAMINE
BOIS ROVERE
TERRANERA.

DETALLE PARED LIVING
CON PUERTAS MANTIS
EN ACABADO LACADO
BEIGE KENIA MATE,
ENCIMERA EN GRES
ACABADO TAJ MAHAL
MATE Y ESPALDA EN
BILAMINADO DE MADERA
ROVERE TERRANERA.

118

119



1
COLONNE COLUMNS COLONNES COLUMNAS
 MANTIS LEGNO SPINA DI PESCE ROVERE MAGMA CON APERTURA GOLA VERTICALE, PUSH-PULL E NICCHIE ILLUMINATE LED. STRUTTURA INTERNA IN FINITURA NERO CARBONE

2
ISOLE ISLANDS ÎLOTS ISLAS
 BLUNA LACCATO LUCIDO BEIGE KENIA PROFILO 30°. WORKTOP SLIDE GRES TAJ MAHAL OPACO. STRUTTURA INTERNA IN NERO CARBONE

3
COLONNE VETRINA GLASS COLUMNS COLONNES VITRINES COLUMNAS VETRINA
 REFLEX VETRO FUMÉ E TELAIO FINITURA ALLUMINIO NERO. STRUTTURA INTERNA IN BILAMINATO LEGNO ROVERE FUMÉ CON SCHIENA GREY FABRIC. RIPIANI IN VETRO FUMÉ

4
MADIA SIDEBBOARD BUFFET PATILLA
 BLUNA LACCATO LUCIDO BEIGE KENIA. INSERTO IN LEGNO SPECIALE ROVERE TERMOTRATTATO. STRUTTURA INTERNA IN FINITURA NERO CARBONE E BASAMENTO IN METALLO NERO OPACO

5
TAVOLO TABLE TABLE MESA
 MOOR 04 STRUTTURA IN LEGNO ROVERE CARBONE E PIANO IN GRES FINITURA TAJ MAHAL OPACO

6
SOGGIORNO LIVING WALL MUR DE SÉJOUR MURO DE SALÒN
 MANTIS LACCATO OPACO BEIGE KENIA, BOISERIE LEAF BILAMINATO LEGNO ROVERE TERRANERA CON MENSOLE LED LACCATO OPACO NERO TRAFFICO, PIANO IN GRES FINITURA TAJ MAHAL OPACO. STRUTTURA INTERNA IN NERO CARBONE

120

MANTIS + BLUNA

SCHEDA TECNICA DATA SHEET
FICHE TECHNIQUE FICHA DE DATOS

121

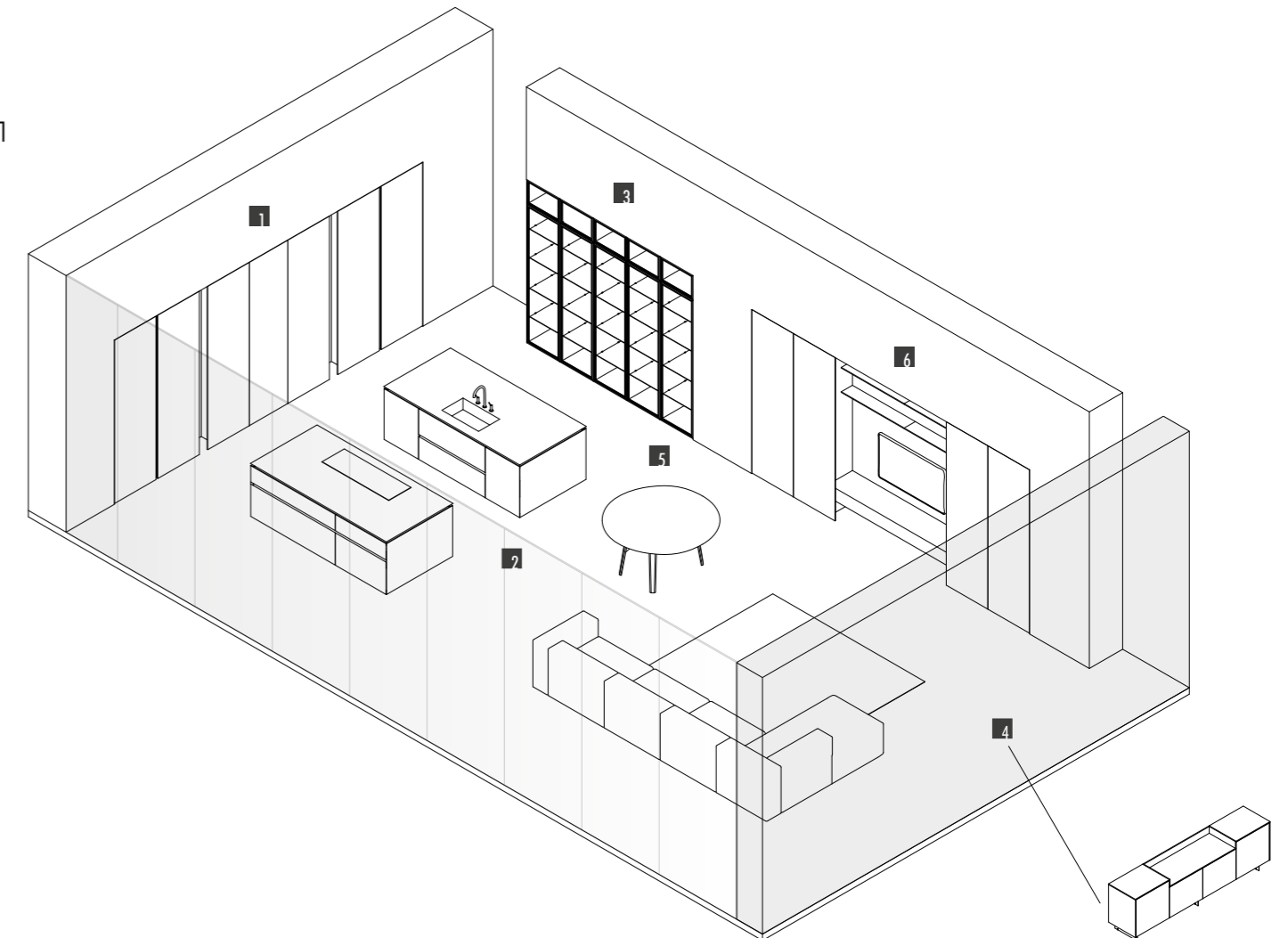

122

123

BLUNA + VOGUE



BLUNA + VOGUE

IL FASCINO DI CIÒ CHE È CELATO.

125

Un inno alla purezza estetica, come un solido perfetto i tagli a 45° alle estremità dell'isola eliminano ogni linea superflua. Il risultato è una sintesi di pulizia e forma, per un ambiente esclusivo ed elegante. Senza dimenticare la funzione di una cucina, da sfruttare pienamente nella sua interezza in uno spazio fluido e senza tempo. Al centro della stanza sovrasta una immensa isola, con ante in laccato opaco taglio 30° in perfetto accordo con il top Limha taglio 60°, la purezza di linee viene interrotta dal monoblocco lavello poggiate su basi ribassate, che consente un comodo spazio per la preparazione dei cibi. Altro elemento di rottura di questa linea infinita è il piano snack che guarda la libreria retrostante. Un'isola che funge da punto di raccordo tra due spazi di contenimento, uno specifico per la refrigerazione e l'altro per la cottura. Le colonne sono contraddistinte dalla maniglia verticale Vogue, elemento di forte carattere. L'intera cucina è realizzata con il nuovo modulo 75, in perfetta linea con le esigenze della contemporaneità. L'ambiente si conclude con un'ampia zona living posta nel retro caratterizzata da una parete di vetro accostata ad un camino a pavimento ed una madia che ripercorre le medesime finiture utilizzate in cucina. A hymn to aesthetic purity, like a perfect block, the 45° cuts at the ends of the island eliminate any unnecessary lines. The result is a synthesis of cleanliness and form, for an exclusive and elegant environment. Without forgetting the function of a kitchen, to be fully exploited in its entirety in a fluid and timeless space. In the center of the room there is an immense island, with 30° cut matt lacquered doors in perfect harmony with the 60° cut Limha top, the purity of lines is interrupted by the monoblock sink resting on lowered bases, which allows a comfortable space for food preparation. Another element of breakthrough of this infinite line is the snack top that looks at the bookcase behind it. An island that acts as a meeting point between two containment spaces, one specific for refrigeration and the other for cooking. The columns are characterized by the Vogue vertical handle, an element of strong character. The entire kitchen is made with the new module 75, in perfect line with the requirements of the contemporary world. The environment ends with a large living area located on the back, characterized by a glass wall placed side by side with a fireplace on the floor and a sideboard that traces the same finishes used in the kitchen.

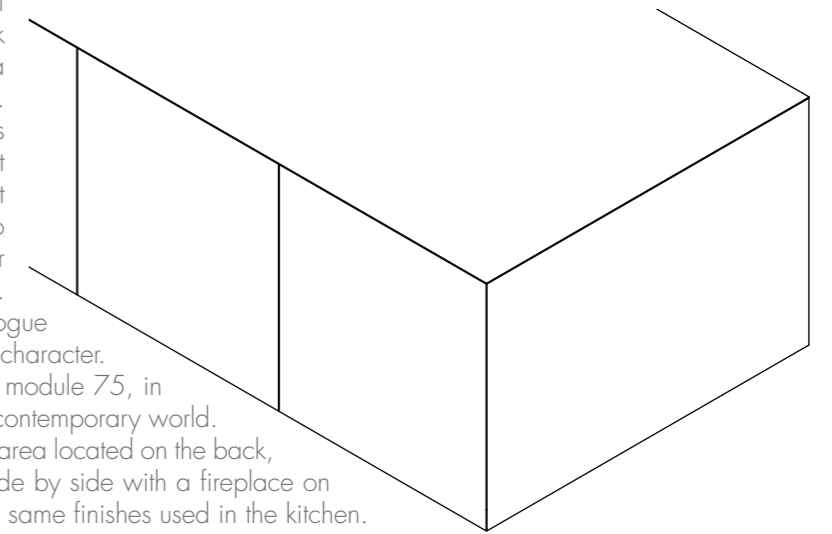





128

129



**DETTAGLIO COLONNE
VOGUE LEGNO
SPECIALE ROVERE
VESUVIO DOGA
SFALSATA CON
MANIGLIA INTEGRATA
LACCATO OPACO.
MONOBLOCCO LAVELLO
IN GRES INSIDE
PIETRA PIASENTINA
GRIGIO FIAMMATO CON
LAVORAZIONE RIGATA
SUL FRONTALE.**

**DETAIL OF VOGUE
COLUMNS SPECIAL
WOOD ROVERE
VESUVIO DOGA
SFALSATA FINISH WITH
MATT LACQUERED
INTEGRATED HANDLE.
SINK MONOBLOCK
INSIDE GRES PIETRA
PIASENTINA GRIGIO
FIAMMATO FINISH
WITH RIBBED
CUSTOMIZATION.**

**DETAIL COLONNES
VOGUE BOIS SPECIAL
ROVERE VESUVIO
AVEC LATTES
IRREGULIERES AVEC
POIGNEE INTEGREE
LAQUEE MAT.
MONOBLOC EVIER
EN GRES INSIDE
PIETRA PIASENTINA
GRIGIO FIAMMATO
AVEC RAYURES SUR
L'AVANT.**

**DETALLE COLUMNAS
VOGUE DE MADERA
ESPECIAL ROVERE
VESUVIO LISTON
ESCALONADO
CON TIRADOR
INTEGRADO LACA
MATE. MONOBLOQUE
FREGADERO EN
GRES INSIDE PIETRA
PIASENTINA GRIGIO
LLAMA CON TRABAJO
RAYADO EN EL FRENTE.**





DETTAGLIO ISOLA CON ANTE BLUNA LACCATO OPACO CARRUBA PROFILO 30°, TOP LIMHA IN FINITURA GRES INSIDE PIETRA PIASENTINA GRIGIO FIAMMATO. PIANO SNACK IN FINITURA LEGNO ROVERE VESUVIO DOGA SFALSATA CON BORDO INCLINATO.

DETAIL OF ISLAND WITH BLUNA MATT LACQUERED CARRUBA 30° PROFILE DOORS, LIMHA WORKTOP INSIDE GRES PIETRA PIASENTINA GRIGIO FIAMMATO FINISH. SNACK PLAN IN WOOD ROVERE VESUVIO DOGA SFALSATA FINISH WITH INCLINED EDGE.

DETAIL ILOT AVEC FAÇADES BLUNA LAQUEES MAT CARRUBA PROFIL 30°, PLAN LIMHA EN FINITION GRES INSIDE PIETRA PIASENTINA GRIGIO FIAMMATO. PLAN SNACK EN FINITION BOIS ROVERE VESUVIO AVEC LATTES IRREGULIERES AVEC BORD INCLINE.

DETALLE ISLA CON PUERTAS BLUNA LACA MATE CARRUBA PERFIL 30°, ENCIMERA LIMHA EN FINITURA GRES INSIDE PIETRA PIASENTINA GRIGIO LLAMA. ENCIMERA SNACK EN ENCHAPADO DE MADERA ACABADO ROVERE VESUVIO LISTON ESCALONADO CON CANTO INCLINADO.

132

133

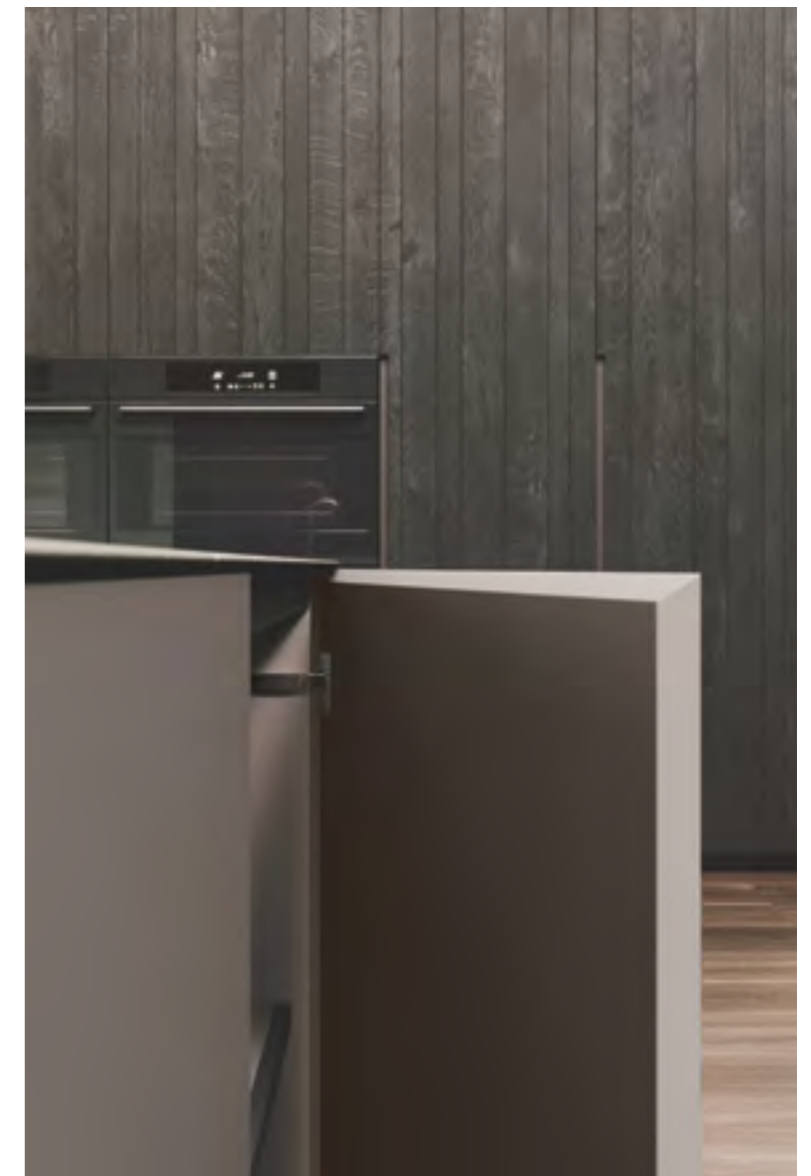



134

135



BOISERIE CON
MENSOLE LED E
PIANO SNACK IN
FINITURA LEGNO
ROVERE VESUVIO
DOGA SFALSATA CON
BORDO INCLINATO
E SCHIENALE IN
GRES INSIDE PIETRA
PIASENTINA GRIGIA
FIAMMATO CON
LAVORAZIONE RIGATA
SUL FRONTALE.

BOISERIE WITH LED
SHELVES AND SNACK
PLAN IN WOOD
ROVERE VESUVIO
DOGA SFALSATA
FINISH WITH
INCLINED EDGE, BACK
PANELS INSIDE GRES
PIETRA PIASENTINA
GRIGIO FIAMMATO
FINISH WITH RIBBED
CUSTOMIZATION ON
FRONT.

BOISERIE AVEC
ETAGERES LED ET
PLAN SNACK EN
FINITION BOIS
ROVERE VESUVIO
AVEC LATTES
IRREGULIERES AVEC
BORD INCLINE ET
DOS EN GRES INSIDE
PIETRA PIASENTINA
GRIGIO FIAMMATO
AVEC RAYURES SUR LA
PARTIE AVANT.

BOISERIE CON
ESTANTES LED Y
ENCIMERA SNACK
EN MADERA ROVERE
VESUVIO LISTON
ESCALONADO CON
CANTO INCLINATO
Y SALPICADERO EN
GRES INSIDE PIETRA
PIASENTINA GRIS
LLAMA CON TRABAJO
RAYADO EN EL
FRENTE.

DETTAGLIO MADIA
CON ANTE VOGUE
LEGNO IN FINITURA
ROVERE VESUVIO
DOGA SFALSATA E
TOP IN GRES INSIDE
FINITURA PIETRA
PIASENTINA GRIGIO
FIAMMATO.

DETAIL OF SIDEBOARD
WITH VOGUE DOORS
WOOD ROVERE
VESUVIO DOGA
SFALSATA FINISH,
WORKTOP INSIDE
GRES PIETRA
PIASENTINA GRIGIO
FIAMMATO FINISH.

DETAIL BUFFET AVEC
FAÇADES VOGUE BOIS
EN FINITION ROVERE
VESUVIO AVEC LATTES
IRREGULIERES ET
PLAN EN GRES INSIDE
FINITION PIETRA
PIASENTINA GRIGIO
FIAMMATO.

DETALLE APARADOR
CON PUERTAS
VOGUE MADERA EN
ACABADO DE ROVERE
VESUVIO CON LISTON
ESCALONADO Y
ENCIMERA EN GRES
INSIDE PIETRA
PIASENTINA LLAMA.

136

137







DETTAGLIO PARETE LIVING CON PENSILI IN VETRO REFLEX CON TELAIO IN ALLUMINIO NERO E VETRO FUMÈ. STRUTTURA IN BILAMINATO MATERICO BETON ARGILLA E SCHIENALE IN FINITURA GREY FABRIC.

DETAIL OF WALL UNITS WITH REFLEX GLASS DOORS MADE IN BLACK ALUMINIUM FRAME AND FUMÈ GLASS. STRUCTURE IN MATERIC BILAMINATE BETON ARGILLA FINISH AND BACK PANEL IN GERY FABRIC FINISH.

DETAIL MUR LIVING AVEC MEUBLES HAUTS EN VERRE REFLEX AVEC CADRE EN ALUMINIUM NOIR ET VERRE FUMÉ. STRUCTURE EN BILAMINE BETON ARGILLA ET DOS EN FINITION GREY FABRIC.

DETALLE PARED LIVING CON ALTOS DE VIDRIO RÉFLEX CON MARCO DE ALUMINIO NEGRO Y VIDRIO FUMÉ. ESTRUCTURA EN BILAMINADO MATERICO BETON ARGILLA Y SALPICADERO EN ACABADO GREY FABRIC.



1

COLONNE COLUMNS COLONNES COLUMNAS

VOGUE LEGNO SPECIALE ROVERE VESUVIO DOGA SFALSATA, APERTURA CON MANIGLIA INTEGRATA NELL'ANTA LACCATO OPACO CARRUBA. STRUTTURA INTERNA IN FINITURA NERO CARBONE

2

ISOLA ISLAND ÎLOT ISLA

BLUNA LACCATO OPACO CARRUBA PROFILO 30°, APERTURA PUSH-PULL. WORKTOP LIMHA E MONOBLOCCO LAVELLO GRES INSIDE PIETRA PIASENTINA GRIGIO FIAMMATO. STRUTTURA INTERNA IN NERO CARBONE

3

BASI BASE UNITS MEUBLES BAS MUEBLES BAJOS

BLUNA LACCATO OPACO CARRUBA PROFILO 30°, APERTURA PUSH-PULL. WORKTOP LIMHA GRES INSIDE PIETRA PIASENTINA GRIGIO FIAMMATO. MENSOLE LEGNO ROVERE VESUVIO DOGA SFALSATA. STRUTTURA INTERNA IN NERO CARBONE

4

MADIA SIDEBOARD BUFFET PATILLA

VOGUE LEGNO SPECIALE ROVERE VESUVIO DOGA SFALSATA, APERTURA CON MANIGLIA INTEGRATA NELL'ANTA LACCATO OPACO CARRUBA. PIANO GRES INSIDE PIETRA PIASENTINA GRIGIO FIAMMATO. STRUTTURA INTERNA IN FINITURA NERO CARBONE

5

TAVOLO TABLE TABLE MESA

MOOR 03 STRUTTURA IN LEGNO ROVERE CARBONE E PIANO IN GRES INSIDE FINITURA PIETRA PIASENTINA GRIGIO FIAMMATO

6

SOGGIORNO LIVING WALL MUR DE SÉJOUR MURO DE SALÒN

VETRINE REFLEX VETRO FUMÉ E TELAIO ALLUMINIO NERO. STRUTTURA INTERNA IN BILAMINATO MATERICO BETON ARGILLA CON SCHIENA GREY FABRIC. SCHIENALI IN BILAMINATO MATERICO METALLO BRUNITO

142

BLUNA + VOGUE

**SCHEDA TECNICA DATA SHEET
FICHE TECHNIQUE FICHA DE DATOS**

143

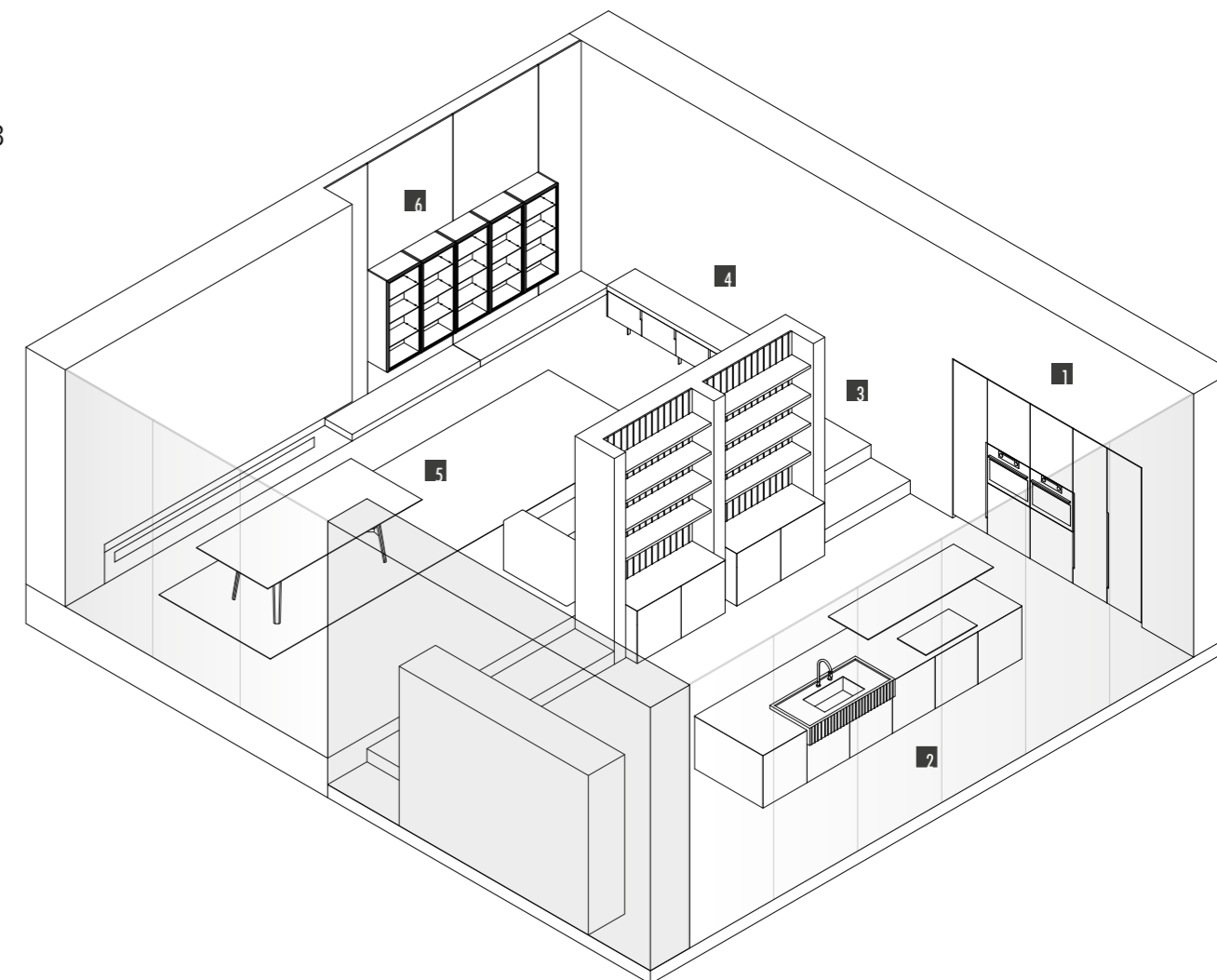

LACCATO OPACO
CARRUBA

LEGNO SPECIALE
ROVERE VESUVIO
DOGA SFALSATA

GRES INSIDE
PIETRA PIASENTINA
GRIGIO FIAMMATO

BILAMINATO
STRUTTURA NERO
CARBONE

BILAMINATO
MATERICO
METALLO BRUNITO

BILAMINATO
MATERICO BETON
ARGILLA

BILAMINATO
STRUTTURA GREY
FABRIC

VETRO FUMÉ E
ALLUMINIO NERO

144

145

BLUNA LEGNO



BLUNA LEGNO

QUANDO UN BINARIO CORRE LUNGO INFINITI PIANI.

147

L'idea di un spazio conviviale è al centro di questo progetto: un'isola dalle dimensioni quadrate fa da padrona e predomina la scena in maniera incontrastata. Il quadrato è inteso come forma accogliente e come elemento attorno al quale poter camminare e trascorrere ogni giorno di vita in completa serenità, valori ancor di più consolidati per mezzo del piano snack che aumenta le possibilità di incontro. Le colonne ed i pensili hanno ante sporgenti di 15 cm rispetto alle strutture che interrompono la monotonia dei frontali ripetuti ed al contempo consentono una comoda presa per l'apertura, il vuoto rompe gli equilibri ed al contempo genera una libreria o semplicemente un cono di luce. I materiali utilizzati sono dal sapore classico, un bilaminato materico Pietra piacentina è accostato al legno Rovere grigio Londra. A completamento dell'ambiente si accostano una parete living che ripercorre gli stessi materiali della cucina e che si arricchisce di vetrine Reflex che conferiscono luce e dinamismo alla composizione basata sul concetto di piani sfalsati. Fanno da sfondo un tavolo e delle colonne basse. The idea of a convivial space is at the center of this project: an island with squared shape dominates the scene in an undisputed way. The square symbolizes a comfortable shape, like an element around you can walk and spend every day of life in complete serenity, values also consolidated thanks to the snack plane that increases the meeting possibilities. The columns and wall units have 15 cm projecting doors relative to the structure that interrupt the monotony of the repeated fronts and at the same time allow a comfortable grip for opening, the empty areas break the balance and at the same time generate a library or simply a cone of light. Used materials have a classic flavor, a materic bilaminated Pietra piacentina is matched with Rovere grigio Londra oak wood. To complete the environment, there is a living wall that retraces the same materials of the kitchen and which is enriched with Reflex wall units that give light and with staggered plans for a beautiful dynamism. As a background a table and low columns.

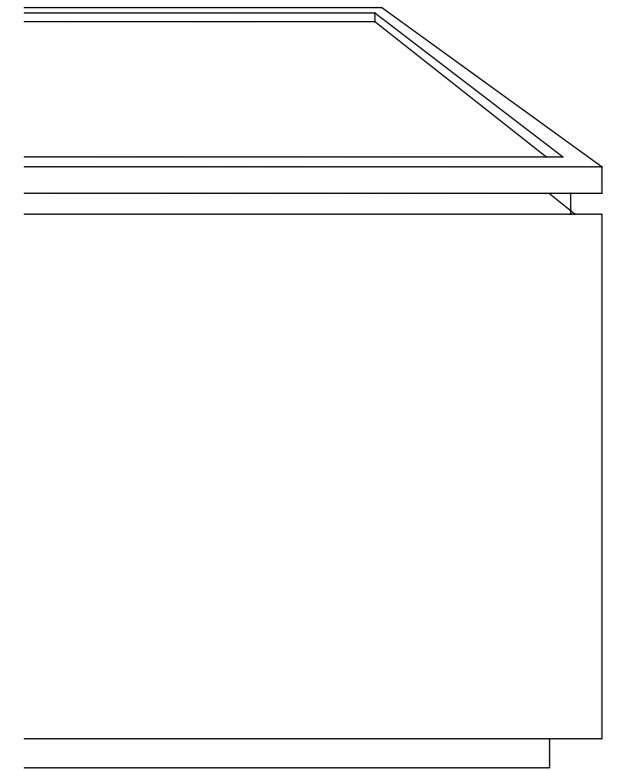





150

151

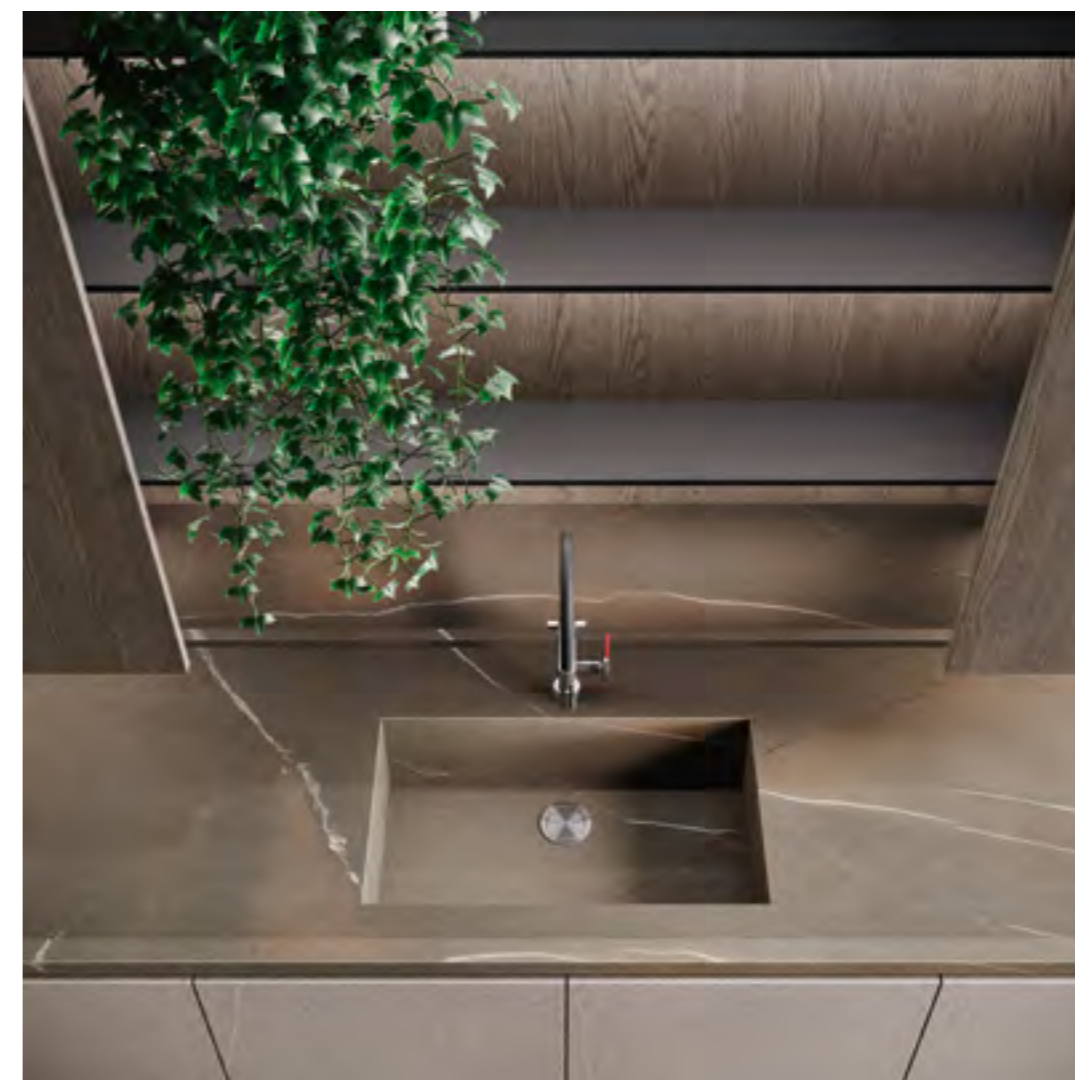

DETTAGLIO BASI
CON ANTE IN
FINITURA LEGNO
ROVERE GRIGIO
LONDRA PROFILO
30° E BILAMINATO
MATERICO FINITURA
PIETRA PIASENTINA,
TOP RAIL IN GRES
INSIDE FINITURA
PIETRA PIASENTINA
TAUPE FIAMMATO.

DETAIL OF BASE
UNITS WITH WOOD
ROVERE GRIGIO
LONDRA FINISH
30° PROFILE AND
MATERIC BILAMINATE
PIETRA PIASENTINA
FINISH, RAIL
WORKTOP INSIDE
GRES PIETRA
PIASENTINA TAUPE
FIAMMATO FINISH.

DETAILS DES
MEUBLES BAS AVEC
PORTES EN FINITION
BOIS ROVERE GRIGIO
LONDRA PROFIL
30° ET BILAMINE
FINITION PIETRA
PIASENTINA, PLAN
EN GRES INSIDE
FINITION PIETRA
PIASENTINA TAUPE
FIAMMATO.

DETALLE DE BAJO CON
PUERTAS ENCHAPADAS
DE MADERA ACABADO
ROVERE GRIGIO LONDRA
PERFIL 30° Y MATERIAL
BILAMINADO MATERICO
ACABADO PIETRA
PIASENTINA, TOP
RAIL EN GRES INSIDE
ACABADO PIETRA
PIASENTINA TAUPE
LLAMA.





DETTAGLIO COLONNE
CON ANTA SPORGENTE
DI 15 CM RISPETTO
ALLA STRUTTURA
IN BILAMINATO
MATERICO FINITURA
PIETRA PIASENTINA
E PENSILI BLUNA
LEGNO IN FINITURA
ROVERE GRIGIO
LONDRA.

DETAIL OF COLUMNS
THAT HAVE 15 CM
PROJECTING DOORS
RELATIVE TO THE
STRUCTURE IN
MATERIC BILAMINATE
PIETRA PIASENTINA
AND WALL UNITS
BLUNA WOOD ROVERE
GRIGIO LONDRA
FINISH.

DETAIL COLONNES
AVEC PORTE QUI
DEPASSE DE 15CM
PAR RAPPORT A
LA STRUCTURE EN
BILAMINE FINITION
PIETRA PIASENTINA
ET MEUBLES HAUTS
BLUNA BOIS EN
FINITION ROVERE
GRIGIO LONDRA.

DETALLES DE
COLUMNAS CON PUERTA
SALIENTE DE 15 CM
EN COMPARACIÓN CON
LA ESTRUCTURA EN
BILAMINADO MATERICO
ACABADO PIETRA
PIASENTINA Y ALTOS
DE PARED ENCHAPADO
DE MADERA ACABADO
ROVERE GRIGIO LONDRA.

154

155





156

157

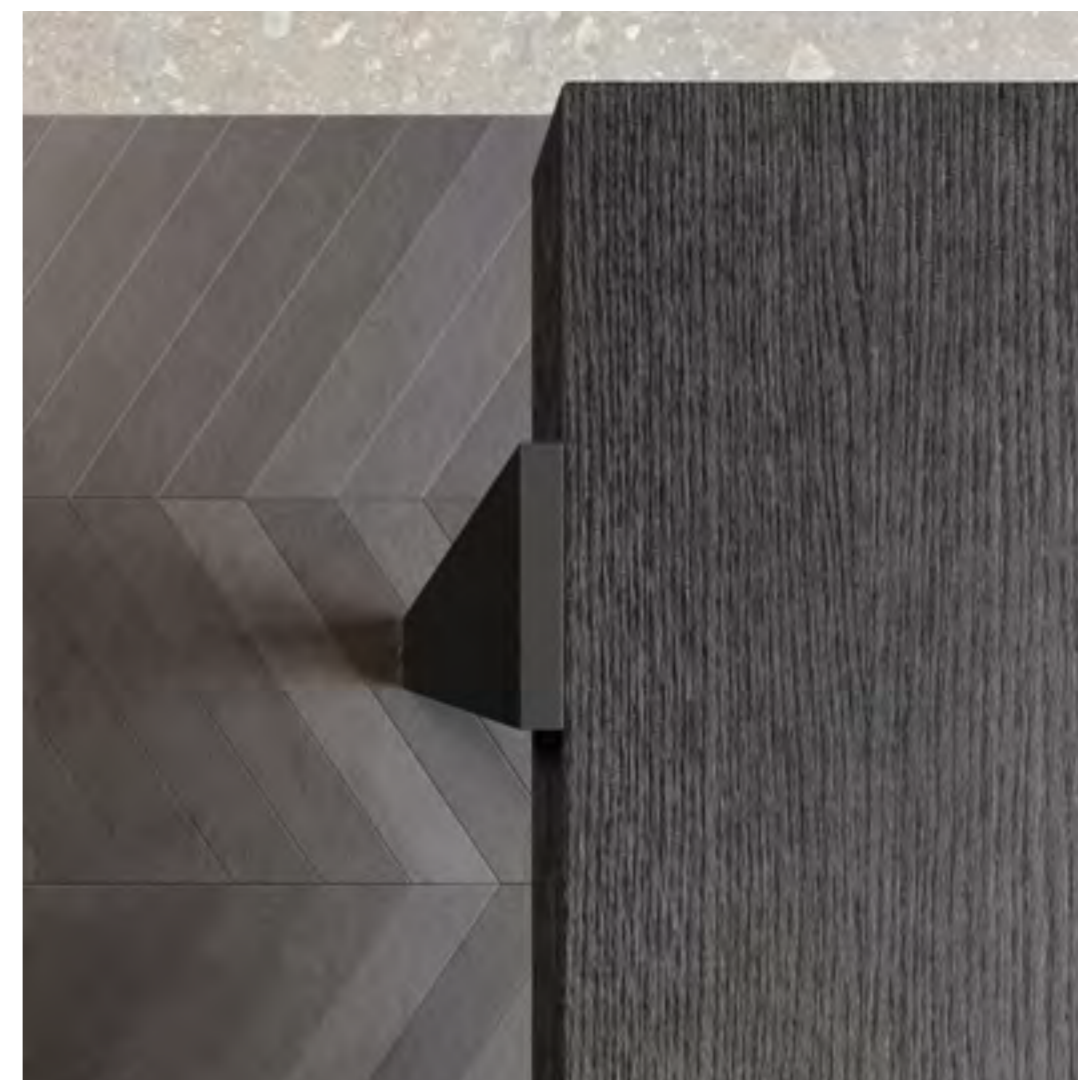

DETTAGLIO PIANO
SNACK IN FINITURA
LEGNO ROVERE
CARBONE E GAMBA
H-SHAPE FINITURA
NERO OPACO.

DETAIL OF SNACK
PLAN IN WOOD
ROVERE CARBONE
FINISH AND H-SHAPE
LEG MATT BLACK
FINISH.

DETAIL PLAN SNACK
EN FINITION BOIS
ROVERE CARBONE
ET JAMBAGE
H-SHAPE FINITION
NOIR MAT.

DETALLE PLAN SNACK
ENCHAPADO DE MADERA
ACABADO ROVERE
CARBONE Y PATA
H-SHAPE ACABADO
MATE NEGRO.

DETTAGLIO COLONNE
BASSE CON ANTE
BLUNA IN FINITURA
LEGNO ROVERE
GRIGIO LONDRA
E ANTE IN VETRO
REFLEX CON TELAIO
NERO E VETRO FUMÈ.

DETAIL OF LOWER
COLUMN IN BLUNA
WOOD ROVERE GRIGIO
LONDRA FINISH AND
REFLEX GLASS DOORS
MADE IN BLACK
ALUMINUM FRAME
AND FUMÈ GLASS.

DETAIL COLONNES
BASSES AVEC FAÇADES
BLUNA EN FINITION
BOIS ROVERE GRIGIO
LONDRA ET PORTES
EN VERRE REFLEX
AVEC CADRE NOIR ET
VERRE FUMÈ.

DETTALLES COLUMNAS
BAJAS CON PUERTAS
BLUNA ENCHAPADO DE
MADERA ACABADO ROVERE
GRIGIO LONDRA Y PUERTAS
EN VIDRIO REFLEX MARCO
EN ACABADO DE ALUMINIO
NERO MATE VIDRIO FUMÈ'.

158

159







DETTAGLIO PARETE
LIVING CON BASI
SOSPESE IN FINITURA
BLUNA LEGNO
ROVERE GRIGIO
LONDRA, PENSILI
CON ANTE VETRO
REFLEX CON TELAIO
NERO E VETRO
FUMÈ, SCHIENALI
IN BILAMINATO
MATERICO FINITURA
PIETRA PIASENTINA.

DETAIL OF LIVING
WALL WITH BASE UNITS
BLUNA WOOD ROVERE
GRIGIO LONDRA FINISH
AND WALL UNITS
WITH REFLEX GLASS
DOORS MADE IN BLACK
ALUMINUM FRAME
AND FUMÈ GLASS,
BACK PANELS ARE IN
MATERIC BILAMINATE
PIETRA PIASENTINA
FINISH.

DETAIL LIVING
AVEC MEUBLES BAS
SUSPENDUS EN
FINITION BLUNA
BOIS ROVERE GRIGIO
LONDRA, MEUBLES
HAUTS EN VERRE
REFLEX AVEC CADRE
NOIR ET VERRE
FUME', DOS EN
BILAMINE MATERICO
FINITION PIETRA
PIASENTINA.

DETALLE PARED
LIVING CON BAJOS
SUSPENDIDOS BLUNA
ENCHAPADO DE
MADERA ACABADO
ROVERE GRIGIO
LONDRA, ALTOS
EN VIDRIO RÉFLEX
MARCO NERO VIDRIO
FUME', ESPALDA
EN BILAMINADO
MATERICO ACABADO
PIETRA PIASENTINA.

162

163



1
COLONNE COLUMNS COLONNES COLUMNAS
BLUNA BILAMINATO MATERICO PIETRA PIASENTINA CON APERTURA GOLA VERTICALE E NICCHIE ILLUMINATE LED. STRUTTURA INTERNA IN FINITURA GREY FABRIC

2
PENSILI WALL UNITS MEUBLES HAUT MUEBLES ALTOS
BLUNA LEGNO ROVERE GRIGIO LONDRA, BOISERIE LEAF LEGNO ROVERE GRIGIO LONDRA. STRUTTURA INTERNA IN FINITURA GREY FABRIC

3
BASI BASE UNITS MEUBLES BAS MUEBLES BAJOS
BLUNA BILAMINATO MATERICO PIETRA PIASENTINA CON APERTURA GOLA ELLE. STRUTTURA INTERNA IN FINITURA GREY FABRIC

4
ISOLA ISLAND ÎLOT ISLA
BLUNA LEGNO ROVERE GRIGIO LONDRA PROFILO 30°. WORKTOP RAIL GRES INSIDE PIETRA PIASENTINA TAUPE FIAMMATO. PIANO SNACK IN LEGNO ROVERE CARBONE CON GAMBA H-SHAPE IN METALLO NERO OPACO. STRUTTURA INTERNA IN FINITURA GREY FABRIC

5
COLONNE BASSE LOWER COLUMNS COLONNES BASSES COLUMNAS BAJAS
BLUNA LEGNO ROVERE GRIGIO LONDRA, BOISERIE LEAF LEGNO ROVERE GRIGIO LONDRA. VETRINE REFLEX VETRO FUMÉ E TELAIO ALLUMINIO NERO. STRUTTURA INTERNA IN BILAMINATO MATERICO BETON VULCANO CON SCHIENA NERO CARBONE.

6
TAVOLO TABLE TABLE MESA
AFFIORO STRUTTURA IN LEGNO ROVERE GRIGIO LONDRA E PIANO IN GRES INSIDE FINITURA PIETRA PIASENTINA TAUPE FIAMMATO

7
SOGGIORNO LIVING WALL MUR DE SÉJOUR MURO DE SALÒN
BLUNA LEGNO ROVERE GRIGIO LONDRA, VETRINE REFLEX VETRO FUMÉ E TELAIO ALLUMINIO NERO. STRUTTURA INTERNA IN BILAMINATO MATERICO BETON VULCANO CON SCHIENA NERO CARBONE. SCHIENALI IN BILAMINATO MATERICO PIETRA PIASENTINA. STRUTTURA INTERNA IN FINITURA GREY FABRIC

164

BLUNA LEGNO

SCHEDA TECNICA DATA SHEET
FICHE TECHNIQUE FICHA DE DATOS

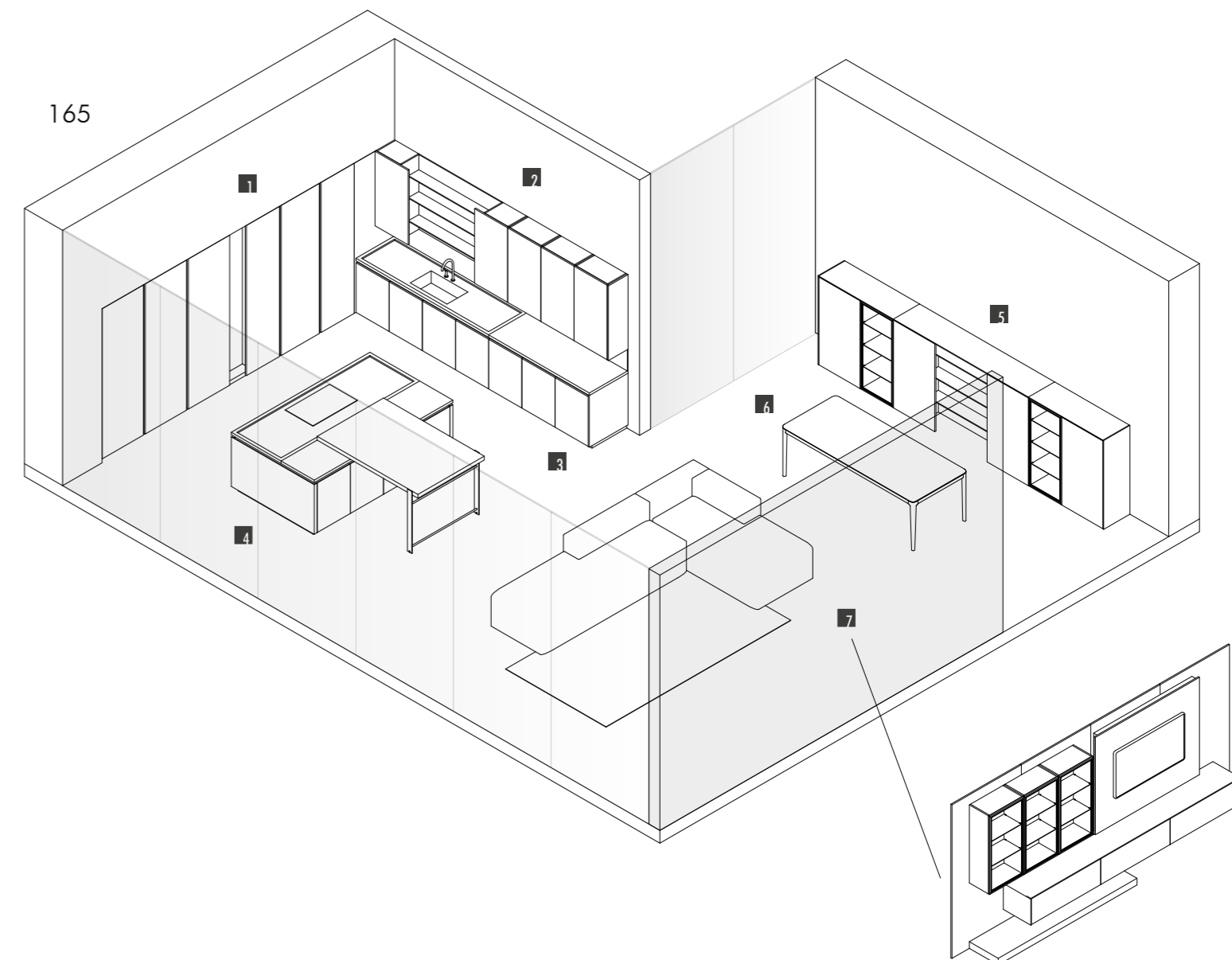

166

167

VOGUE + BLUNA

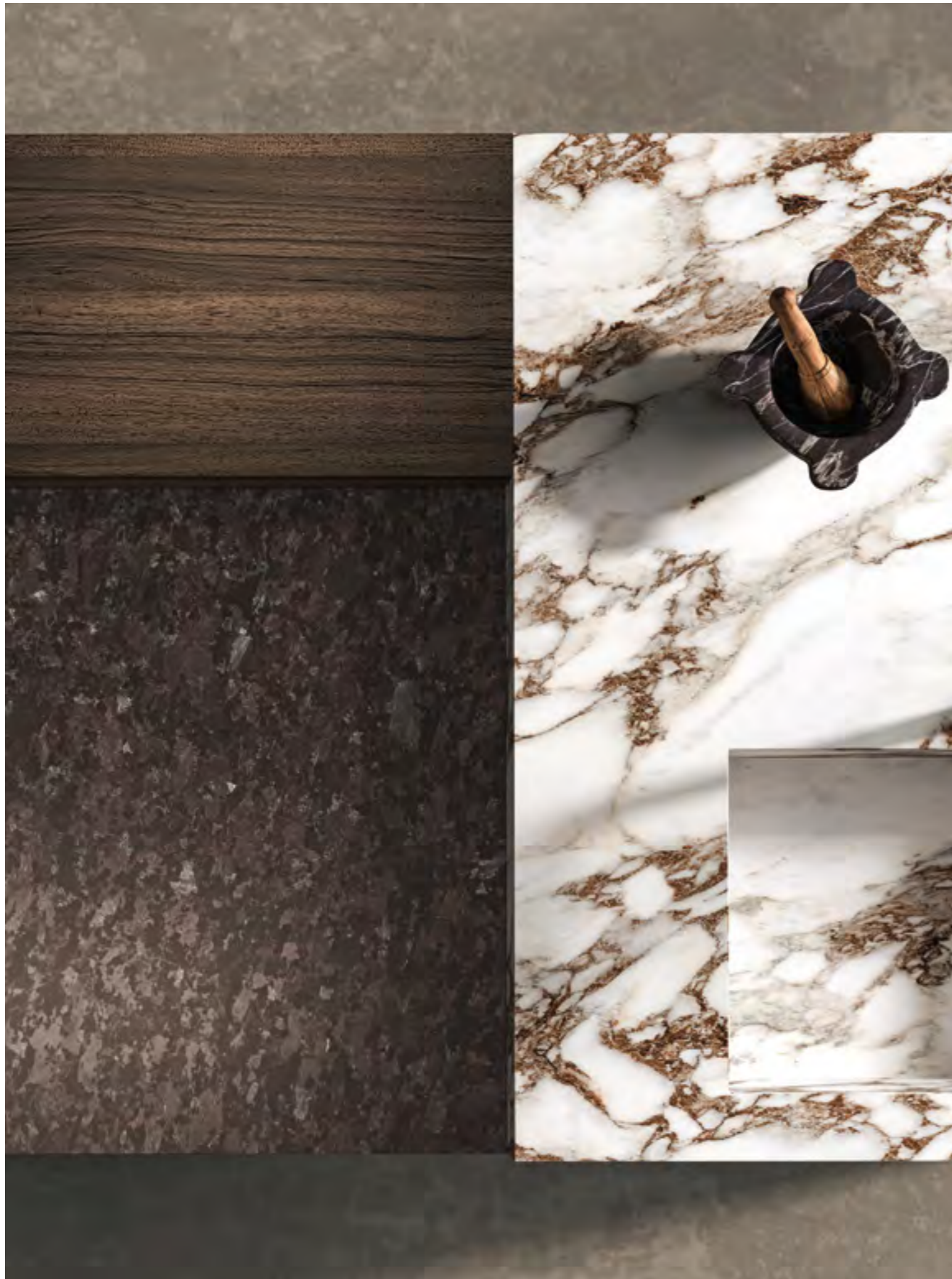

VOGUE + BLUNA

L'UTILITÀ ESSENZIALE DEL VUOTO.

169

Binova propone un nuovo percorso di esplorazione attorno alla relazione tra la cucina e le altre aree della casa, in un continuo intrecciarsi di funzioni, abitudini e bisogni del quotidiano. Gli spazi smettono di essere limitati da elementi strutturali per diventare zone aperte e di passaggio, in cui non esiste più una vera gerarchia operativa. Un progetto che definisce così lo spirito di una casa aperta che non teme di offrire prospettive informali, dove il mutare della percezione dello spazio è un valore e non una stravaganza. L'elemento principale attorno al quale ruota l'intero ambiente è la parete colonne ad L costituita da moduli di diverse profondità uniti assieme per costituire un'unica linea che congiunge la cucina al living e che utilizza i medesimi elementi, un "continuum" di contaminazioni tra forme e funzioni. Altra forte caratteristica delle colonne sono le aperture che alleggeriscono l'impatto del muro in legno ed al contempo consentono l'apertura dei frontali e dei meravigliosi coni di luce. L'isola con ante Vogue è caratterizzata da tagli verticali che consentono l'apertura e dalla finitura laccata ossidata, altro elemento innovativo è il piano snack a sbalzo totale che garantisce un'area conviviale comoda. La parete living ripercorre le stesse finiture della cucina ed è caratterizzata da una intersezione di volumi che consentono pieni e vuoti con vani folding incassati, mentre la madia è con ante Vogue e top in gres alto spessore. Binova propone a new exploration of the relationship between kitchen and living area, the continuous interlacing of functions, rituals and daily needs. Spaces are no longer limited by structural elements becoming open areas where an operating hierarchy doesn't exist anymore. A project that defines the spirit of an open home that is no longer afraid of an informal outlook, where the perception of space is changing, no longer an extravagance. The main element around which the entire room revolves is the L-shaped column wall made up of modules of different depths joined together to form a single line that connects the kitchen from the living room and uses the same elements, a "continuum" of contamination between forms and functions. Another strong feature of the columns are the openings that lighten the impact of the wooden wall and at the same time allow the opening of the fronts and the wonderful light cones. The island with Vogue doors is characterized by vertical cuts that allow opening and by 4.0 metal lacquered finish, another innovative element is the cantilevered snack top which guarantees a comfortable convivial area. The living wall traces the same finishes as the kitchen and is characterized by an intersection of volumes that allow full and empty spaces with recessed folding open units, while the sideboard is with Vogue doors and top in thick gres.





172



173

DETTAGLIO ISOLA
CON ANTE VOGUE CON
MANIGLIA INTEGRATA
IN FINITURA LACCATO
METAL 4.0 AMARANTO.
TOP IN GRES OPACO
FINITURA BRECCIA
CAPRAIA.

ISLAND DETAIL
OF VOGUE DOORS
WITH INTEGRATED
HANDLE IN 4.0 METAL
LACQUERED AMARANTO
FINISH. WORKTOP IN
MATT GRES BRECCIA
CAPRAIA FINISH.

DETAIL ILOT AVEC
FAÇADES VOGUE AVEC
POIGNÉE INTÉGRÉE EN
FINITION LAQUE METAL
4.0 ROSSO AMARANTO.
PLAN DE TRAVAIL
EN GRÈS FINITION
BRECCIA CAPRAIA MAT.

DETALLE ISLA CON
PUERTAS DE VOGUE CON
TIRADOR INTEGRADO
ACABADO LACADO METAL
4.0 ROJO AMARANTO.
ENCIMERA EN GRES
OPACO ACABADO
BRECCIA CAPRAIA.





DETTAGLIO COLONNA
ANTE RIENTRANTI
FORNO E MICRO IN
FINITURA BLUNA
BILAMINATO LEGNO
ROVERE FUMÈ,
SCHIENALI IN GRES
FINITURA BRECCIA
CAPRAIA OPACO.

DETAIL OF
RETRACTABLE COLUMN
DOORS FOR OVEN
AND MICRO IN BLUNA
BILAMINATE ROVERE
FUMÈ FINISH, BACK
PANELS IN MATT GRES
BRECCIA CAPRAIA
FINISH.

DETAIL COLONNE
PORTES RENTRANTES
FOUR ET MICROONDE
EN FINITION BLUNA
BILAMINE BOIS
ROVERE FUME, DOS
EN GRES FINITION
BRECCIA CAPRAIA
MAT.

DETALLE DE COLUMNA
CON PUERTAS
REENTRANTES HORNO
Y MICRO EN ACABADO
BLUNA BILAMINADO
DE MADERA ROVERE
FUMÈ, ESPALDA EN
GRES MATE ACABADO
BRECCIA CAPRAIA.

176

177

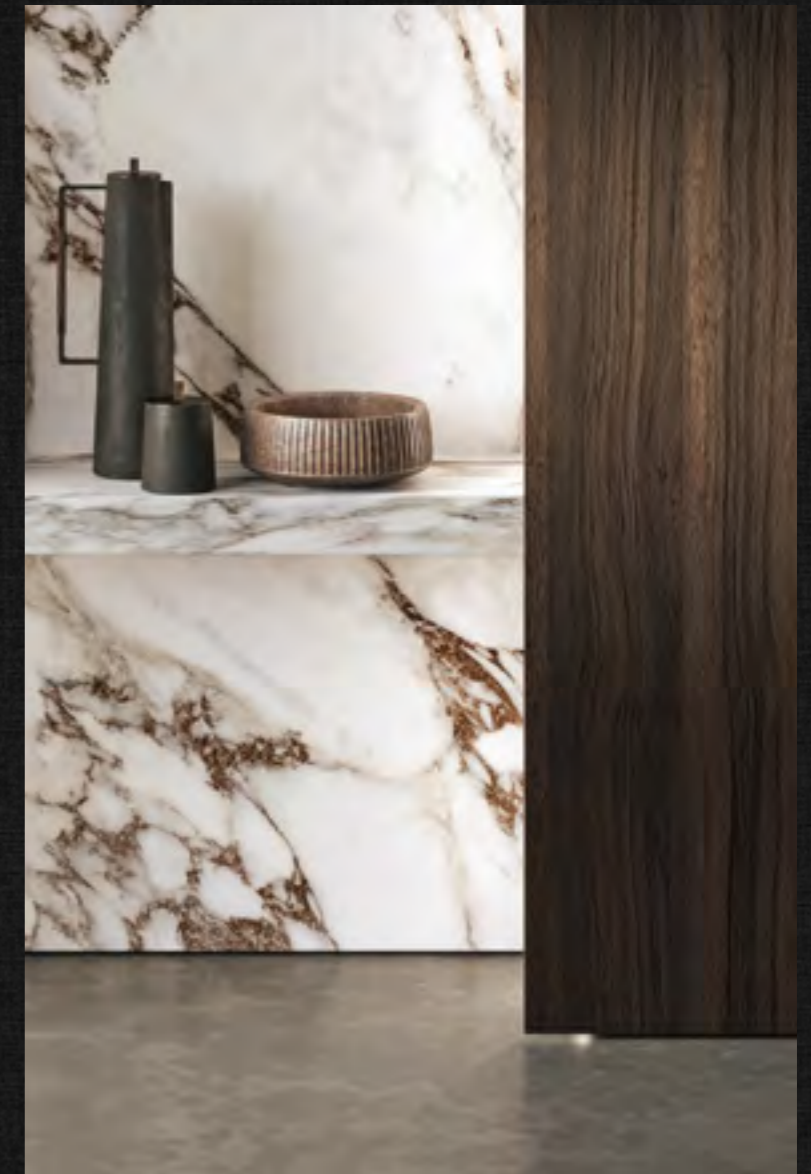



178

179



WORKTOP GRES IN
FINITURA BRECCIA
CAPRAIA OPACO E
PIETRA NATURALE
IN FINITURA BROWN
ANTIQUE. PIANO
SNACK LEGNO IN
FINITURA ROVERE
TERMOTRATTATO.

WORKTOP MATT
GRES BRECCIA
CAPRAIA FINISH AND
NATURAL STONE
BROWN ANTIQUE
FINISH. SNACK
PLAN WOOD ROVERE
TERMOTRATTATO
FINISH.

PLAN DE TRAVAIL
GRÈS EN FINITION
BRECCIA CAPRAIA MAT
ET PIERRE NATURELLE
EN FINITION BROWN
ANTIQUE. PLAN
SNACK BOIS EN
FINITION ROVERE
TERMOTRATTATO.

ENCIMERA EN GRES
OPACO ACABADO EN
BRECCIA CAPRAIA Y
PIEDRA NATURAL
EN ACABADO
BROWN ANTIQUE.
PLAN SNACK EN
ACABADO ROVERE
TERMOTRATTATO.

DETTAGLIO MADIA
CON ANTE VOGUE
LACCATO METAL
4.0 FINITURA
AMARANTO E TOP
IN GRES FINITURA
BRECCIA CAPRAIA
OPACO.

DETAIL OF
SIDEBOARD WITH
VOGUE DOORS IN 4.0
METAL LACQUERED
AMARANTO FINISH,
WORKTOP MATT GRES
BRECCIA CAPRAIA
FINISH.

DETAIL BUFFET AVEC
FAÇADES VOGUE
LAQUEES METAL 4.0
FINITION ROSSO
AMARANTO ET PLAN
DE TRAVAIL EN GRES
FINITION BRECCIA
CAPRAIA MAT.

DETALLE APARADOR
CON PUERTAS VOGUE
LACADO METAL 4.0
ACABADO ROSSO
AMARANTOY ENCIMERA
EN GRES MATE
ACABADO BRECCIA
CAPRAIA.

180

181







DETTAGLIO PARETE LIVING CON ANTE BLUNA LACCATO METAL 4.0 FINITURA AMARANTO, COLONNE IN BLUNA BILAMINATO LEGNO FINITURA ROVERE FUMÈ E MODULI A GIORNO FOLDING NERO OPACO.

DETAIL OF LIVING WITH BLUNA DOORS IN 4.0 METAL LACQUERED AMARANTO FINISH, COLUMNS IN BLUNA WOOD BILAMINATE ROVERE FUMÈ FINISH AND FOLDING OPEN SPACE UNITS MATT BLACK FINISH.

DETAIL MUR LIVING AVEC FAÇADES BLUNA LAQUEES METAL 4.0 FINITION ROSSO AMARANTO, COLONNES BLUNA BILAMINE BOIS FINITION ROVERE FUMÈ ET MEUBLES OUVERTS FOLDING NOIR MAT.

DETALLE PARED LIVING CON PUERTAS LACADO METAL 4.0 ACABADO ROJO AMARANTO, COLUMNAS BLUNA BILAMINADO DE MADERA ACABADO ROVERE FUMÈ Y MÓDULOS ABIERTOS PLEGABLES NEGRO MATE.



1
COLONNE COLUMNS COLONNES COLUMNAS
BLUNA BILAMINATO LEGNO ROVERE FUMÉ CON APERTURA GOLA VERTICALE E NICCHIE ILLUMINATE LED. STRUTTURA INTERNA IN FINITURA NERO CARBONE

2
ISOLA LAVELLO SINK ISLAND ÎLOT ÉVIER ISLA FREGADERO
VOGUE LACCATO METAL 4.0 AMARANTO, APERTURA CON MANIGLIA INTEGRATA NELL'ANTA. WORKTOP GRES BRECCIA CAPRAIA OPACO. STRUTTURA INTERNA NERO CARBONE

3
ISOLA PIANO COTTURA HOB ISLAND ÎLOT PLAQUE ISLA PLACA
VOGUE LACCATO METAL 4.0 AMARANTO, APERTURA CON MANIGLIA INTEGRATA NELL'ANTA. WORKTOP PIETRA NATURALE BROWN ANTIQUE SPAZZOLATO. PIANO SNACK LEGNO ROVERE TERMOTRATTATO. STRUTTURA INTERNA NERO CARBONE

4
MADIA SIDEBOARD BUFFET PATILLA
VOGUE LACCATO METAL 4.0 AMARANTO, APERTURA CON MANIGLIA INTEGRATA NELL'ANTA. PIANO IN GRES BRECCIA CAPRAIA OPACO. BASAMENTO IN METALLO NERO OPACO. STRUTTURA INTERNA NERO CARBONE

5
SOGGIORNO LIVING WALL MUR DE SÉJOUR MURO DE SALÒN
BLUNA LACCATO METAL 4.0 AMARANTO, COLONNE BLUNA BILAMINATO LEGNO ROVERE FUMÉ, MODULI A GIORNO FOLDING LACCATO OPACO NERO TRAFFICO. STRUTTURA INTERNA IN NERO CARBONE

6
TAVOLO TABLE TABLE MESA
T-ONE STRUTTURA IN FINITURA NERO OPACO

186

187

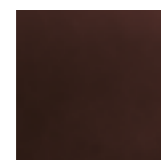
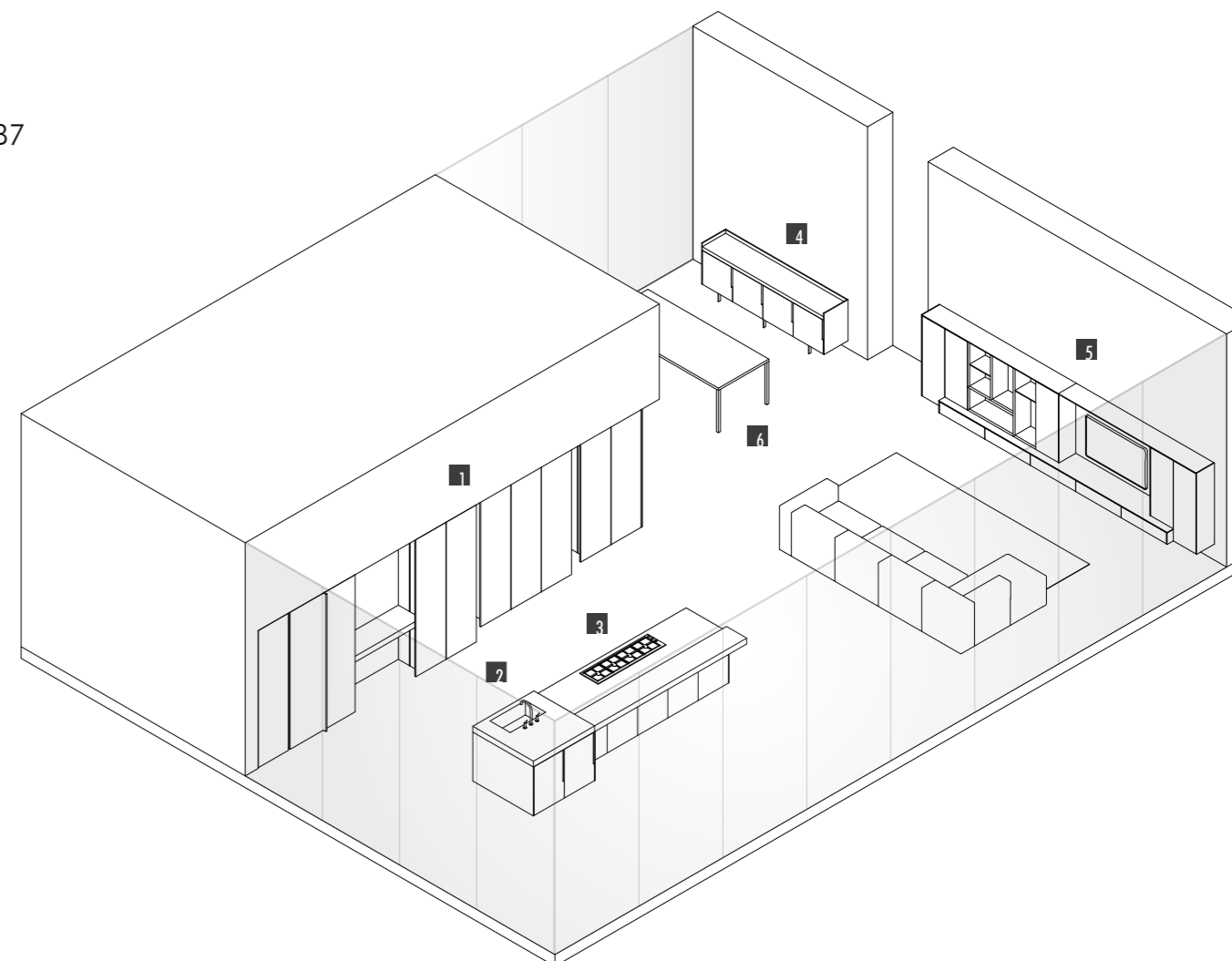

LACCATO METAL
4.0 AMARANTO



BILAMINATO
LEGNO ROVERE
FUMÉ

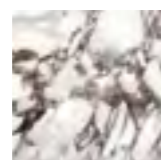

GRES BRECCIA
CAPRAIA OPACO



PIETRA NATURALE
BROWN ANTIQUE
SPAZZOLATO



LEGNO SPECIALE
ROVERE
TERMOTRATTATO

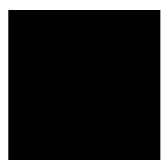

LACCATO OPACO
NERO TRAFFICO



BILAMINATO
STRUTTURA NERO
CARBONE

VOGUE + BLUNA

SCHEDA TECNICA DATA SHEET
FICHE TECHNIQUE FICHA DE DATOS

188

189

BLUNA + LAB



BLUNA + LAB

UN'ANIMA LEGGERA DAL CUORE TECNOLOGICO.

191

Modello deciso e raffinato dalle linee essenziali e dai volumi importanti che esprimano la leggerezza del materiale vetro dei frontali e la solidità del telaio alluminio come sostegno di essi. Progettare all'insegna dell'ergonomia, concentrando nell'isola centrale le zone dedicate al lavaggio e alla cottura per semplificare tutta l'operatività. L'essenzialità dei solidi, sottolineata dalle ante delle colonne e dalle basi dell'isola con gola, non contrasta con le diverse materie traslucide che introducono ad innumerevoli e rigorosi riflessi. Un vero laboratorio dove diversi materiali e finiture sono miscelati con estrema sapienza: le colonne di destra sono Lab in finitura vetro nero traffico opaco, le colonne di sinistra sono Bluna bilaminato legno Noce miele, mentre l'isola è Bluna tech in finitura Alluminio brunito con la nuova gola emme che conferisce una caratteristica leggerezza al top in gres Nero greco di spessore 12 mm. Prominent and refined model with clean lines and large volumes expressing the lightness of the glass fronts and the strength of the aluminum frame supporting them. Design for better ergonomics, concentrating the washing and cooking areas in the central island to make kitchen chores easier. The simplicity of solids, emphasized by tall units doors and island bases with groove, does not contrast with the various translucent materials that introduce countless and rigorous reflections. A real laboratory where different materials and finishes are mixed with extreme knowledge: the right columns are model Lab matt glass Nero traffico finish, the left columns are model Bluna wood bilaminate Noce miele finish, while the island is model Bluna tech Alluminio brunito finish with the new Emme groove which gives a characteristic lightness to the 12 mm thick gres worktop Nero greco finish.





194

195



DETTAGLIO
COLONNA DUE ANTE
RIENTRANTI CON
TELAIO LAB NERO
OPACO CON MANIGLIA
INTEGRATA,
FRONTALE IN VETRO
OPACO FINITURA
NERO TRAFFICO.

DETAIL OF COLUMN
WITH RETRACTABLE
DOORS IN BLACK
ALUMINUM LAB
FRAME WITH
INTEGRATED HANDLE,
FRONT MATT GLASS
NERO TRAFFICO
FINISH.

DETAIL COLONNE
DEUX PORTES
REENTRANTES AVEC
CADRE LAB NOIR
MAT AVEC POIGNEE
INTEGREE, FAÇADE
EN VERRE MAT
FINITION NERO
TRAFFICO.

DETALLE DE
COLUMNNA
DOS PUERTAS
REENTRANTES CON
MARCO LAB NEGRO
MATE CON TIRADOR
INTEGRADO, FRONTAL
DE VIDRIO ACABADO
NEGRO MATE.





DETTAGLIO ANTA
BLUNA TECH IN
FINITURA ALLUMINIO
BRUNITO CON
PROFILO TRIM NERO
E GOLA EMME IN
FINITURA NERO OPACO.
TOP IN FINITURA GRES
NERO GRECO OPACO SP.
12 MM.

DETAIL OF BLUNA
TECH DOOR
ALLUMINIO BRUNITO
FINISH WITH TRIM
PROFILE AND EMME
GROOVE IN MATT
BLACK FINISH.
WORKTOP MATT GRES
NERO GRECO FINISH
12 MM THICKNESS.

DETAIL FAÇADE
BLUNA TECH EN
FINITION ALUMINIUM
BRUNI AVEC PROFIL
TRIM NOIR ET GORGE
EMME EN FINITION
NOIR MAT. PLAN DE
TRAVAIL EN GRES
NERO GRECO MAT
EP.12MM.

DETALLE PUERTA
BLUNA TECH EN
ACABADO DE ALUMINIO
BRUNITO CON PERFIL
TRIM NEGRO Y GOLA
EMME EN ACABADO
NEGRO MATE. TOP EN
GRES ACABADO NEGRO
GRECO MATE
SP. 12 MM.





200

201



DETTAGLIO COLONNE
BLUNA BILAMINATO
LEGNO NOCE MIELE
CON MANIGLIA
TRACCIA FINITURA
NERO OPACO. MODULI
A GIORNO ARNIA
LACCATO OPACO NERO
TRAFFICO.

DETAIL OF BLUNA
WOOD BILAMINATE
NOCE MIELE COLUMN
WITH TRACCIA HANDLE
MATT BLACK FINISH.
OPEN SPACE ARNIA
MATT LACQUERED
NERO TRAFFICO
FINISH.

DÉTAIL COLONNES
BLUNA BILAMINÉ
BOIS NOCE MIELE
AVEC POIGNÉE
TRACCIA FINITION
NOIR MAT. MEUBLES
OUVERTS RUCHE
LAQUÉS MAT NERO
TRAFFICO.

DETALLE COLUMNAS
BLUNA BILAMINADO
DE MADERA NOCE
MIELE CON TIRADOR
TRACCIA ACABADO
MATE NEGRO.
MÓDULOS ABIERTOS
ARNIA LACADO MATE
NEGRO TRAFFICO.

DETTAGLIO MADIA
CON ANTE BLUNA
TECH IN FINITURA
ALLUMINIO BRUNITO
CON PROFILO TRIM
NERO E GOLA ELLE IN
FINITURA NERO OPACO.
TOP IN FINITURA GRES
NERO GRECO OPACO SP.
12 MM.

DETAIL OF SIDEBOARD
WITH BLUNA TECH
DOOR ALLUMINIO
BRUNITO FINISH
WITH TRIM PROFILE
AND ELLE GROOVE IN
MATT BLACK FINISH.
WORKTOP MATT GRES
NERO GRECO FINISH
12 MM THICKNESS.

DETAIL BUFFET AVEC
FAÇADES BLUNA
TECH EN FINITION
ALUMINIUM BRUNI
AVEC PROFIL TRIM
NOIR ET GORGE ELLE
EN FINITION NOIR MAT.
PLAN DE TRAVAIL EN
FINITION GRES NERO
GRECO MAT EP.12MM.

DETALLE APARADOR
CON PUERTAS BLUNA
TECH EN ACABADO DE
ALUMINIO BRUNITO
CON PERFIL TRIM
NEGRO Y GOLA ELLE EN
ACABADO MATE NEGRO.
TOP EN GRES ACABADO
NEGRO GRECO MATE SP.
12 MM.

202

203

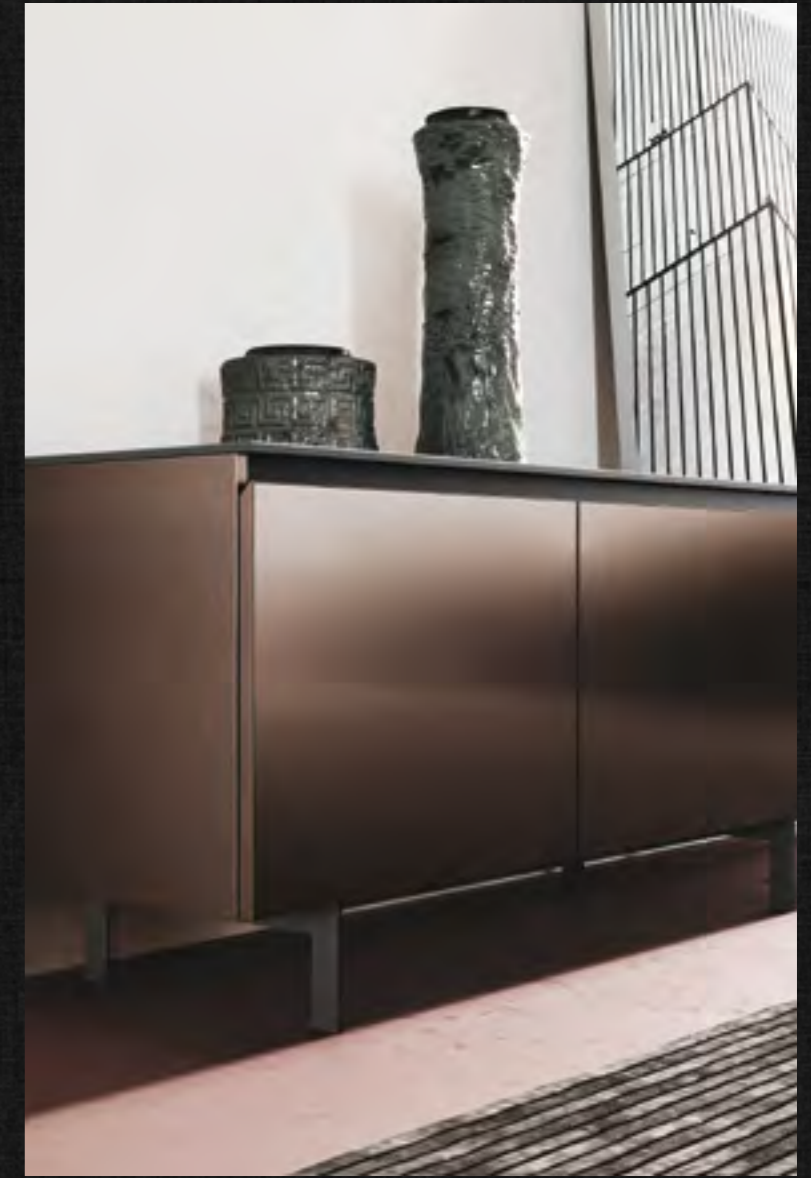





DETTAGLIO LIVING
CON ANTE BLUNA
TECH IN FINITURA
ALLUMINIO BRUNITO
CON PROFILO TRIM
NERO E GOLA ELLE
IN FINITURA NERO
OPACO. TOP IN
FINITURA GRES NERO
GRECO OPACO SP.
12 MM. COLONNE IN
FINITURA BILAMINATO
LEGNO NOCE MIELE.

DETAIL OF SIDEBOARD
WITH BLUNA TECH
DOOR ALLUMINIO
BRUNITO FINISH
WITH TRIM PROFILE
AND ELLE GROOVE IN
MATT BLACK FINISH.
WORKTOP MATT GRES
NERO GRECO FINISH
12 MM THICKNESS.
COLUMNS IN WOOD
BILAMINATE NOCE
MIELE FINISH.

DETAIL LIVING AVEC
FAÇADES BLUNA
TECH EN FINITION
ALUMINIUM BRUNI
AVEC PROFIL TRIM
NOIR ET GORGE
ELLE EN FINITION
NOIR MAT. PLAN DE
TRAVAIL GRES NERO
GRECO MAT EP.12MM.
COLONNES EN
FINITION BILAMINE
BOIS NOCE MIELE.

DETALLE PARED LIVING
CON PUERTAS BLUNA
TECH EN ACABADO DE
ALUMINIO BRUNITO
CON PERFIL TRIM
NEGRO Y GOLA ELLE EN
ACABADO NEGRO MATE.
TOP EN GRES ACABADO
NEGRO GRECO MATE
SP. 12 MM. COLUMNAS
EN ACABADO BLUNA
BILAMINADO DE
MADERA NOCE MIELE.

206

207



1

COLONNE COLUMNS COLONNES COLUMNAS

LAB VETRO OPACO NERO TRAFFICO, APERTURA CON MANIGLIA INTEGRATA NELL'ANTA E GOLA VERTICALE, TELAIO ALLUMINIO NERO OPACO. MODULI A GIORNO ARNIA LACCATO OPACO NERO TRAFFICO. STRUTTURA INTERNA IN FINITURA NERO CARBONE

2

COLONNE COLUMNS COLONNES COLUMNAS

BLUNA BILAMINATO LEGNO NOCE MIELE, APERTURA CON MANIGLIA TRACCIA NERO OPACO. STRUTTURA INTERNA IN NERO CARBONE

3

ISOLA ISLAND ÎLOT ISLA

BLUNA TECH ALLUMINIO BRUNITO CON MANIGLIA PROFILO TRIM, APERTURA CON GOLA EMME NERO TRAFFICO OPACO. WORKTOP GRES NERO GRECO OPACO. STRUTTURA INTERNA NERO CARBONE

4

MADIA SIDEBBOARD BUFFET PATILLA

BLUNA TECH ALLUMINIO BRUNITO CON MANIGLIA PROFILO TRIM, APERTURA CON GOLA ELLE NERO TRAFFICO OPACO. WORKTOP GRES NERO GRECO OPACO. STRUTTURA INTERNA NERO CARBONE

5

TAVOLO TABLE TABLE MESA

PISA STRUTTURA IN LEGNO FINITURA ROVERE CARBONE E PIANO IN GRES FINITURA NERO GRECO OPACO

6

SOGGIORNO LIVING WALL MUR DE SÉJOUR MURO DE SALÒN

BLUNA TECH ALLUMINIO BRUNITO CON MANIGLIA PROFILO TRIM, APERTURA CON GOLA ELLE NERO TRAFFICO OPACO. WORKTOP GRES NERO GRECO OPACO. COLONNE BASSE BLUNA BILAMINATO LEGNO NOCE MIELE. BOISERIE LEAF BILAMINATO LEGNO NOCE MIELE CON MENSOLE LED LACCATO OPACO NERO TRAFFICO. STRUTTURA INTERNA NERO CARBONE

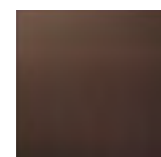

BILAMINATO
TECH ALLUMINIO
BRUNITO



VETRO NERO
TRAFFICO OPACO



BILAMINATO
LEGNO NOCE MIELE



GRES NERO GRECO
OPACO



LACCATO OPACO
NERO TRAFFICO

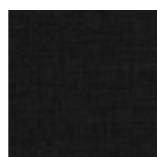

BILAMINATO
STRUTTURA NERO
CARBONE

208

BLUNA + LAB

**SCHEDA TECNICA DATA SHEET
FICHE TECHNIQUE FICHA DE DATOS**

209

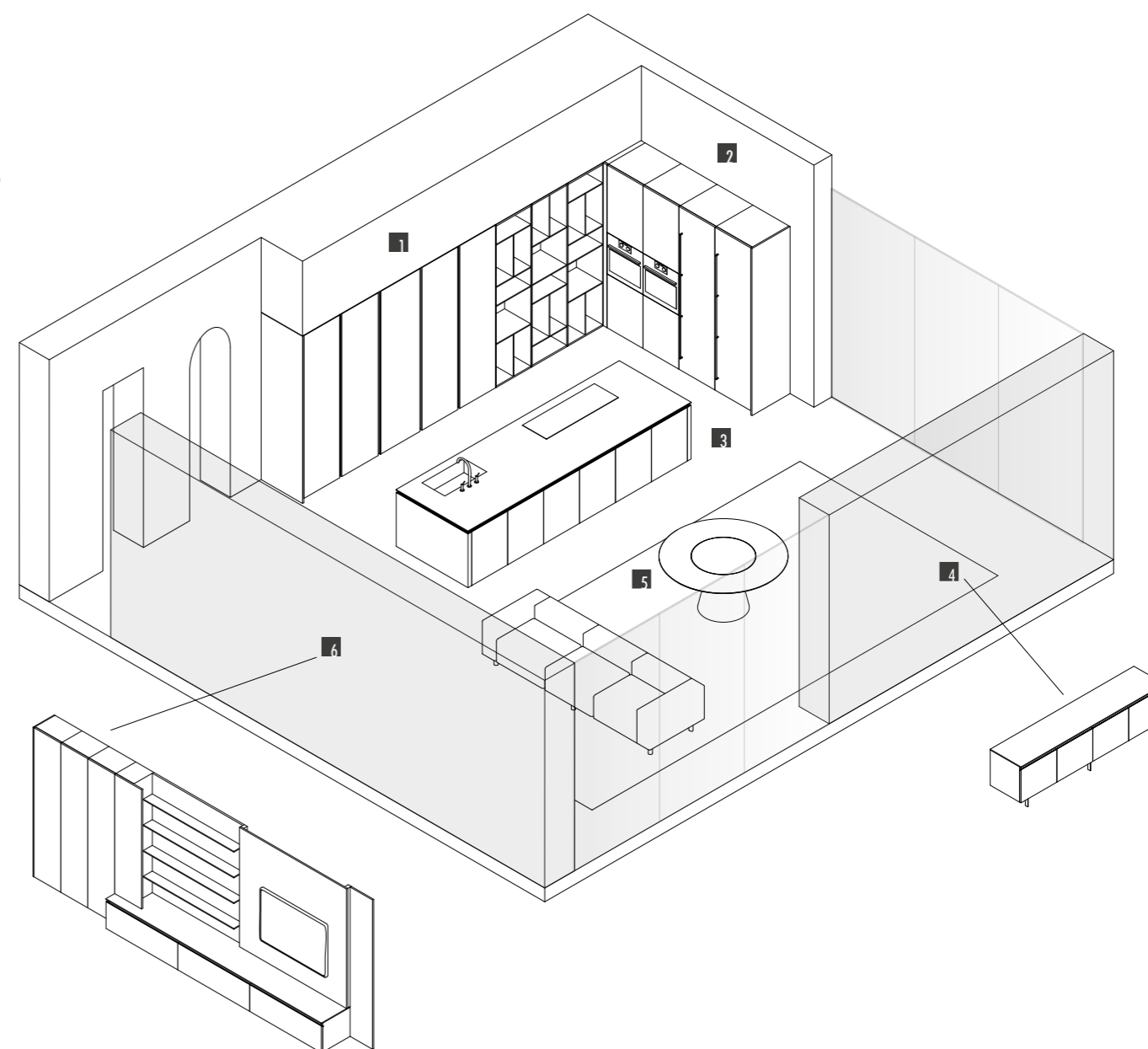

210

211

BLUNA TECH



214

215



216



217

DETTAGLIO PENISOLA
CON ANTE BLUNA
LEGNO ROVERE
CARBONE E GOLA ELLE
IN FINITURA NERO
OPACO. TOP IN GRES
FINITURA EMPERADOR
OPACO E PIETRA
NATURALE FINITURA
BROWN ANTIQUE.

DETAIL OF BLUNA
WOOD DOORS ROVERE
CARBONE FINISH
WITH ELLE GROOVE
MATT BLACK FINISH.
WORKTOP MATT GRES
EMPERADOR FINISH
AND NATURAL STONE
BROWN ANTIQUE
FINISH.

DETAIL PENINSULE AVEC
FAÇADES BLUNA BOIS
ROVERE CARBONE ET
GORGE ELLE EN FINITION
NOIR MAT. PLAN DE
TRAVAIL EN GRES
FINITION EMPERADOR
MAT ET PIERRE
NATURELLE FINITION
BROWN ANTIQUE.

DETALLE DE PENÍNSULA
CON PUERTAS DE
MADERA DE ROVERE
CARBONE Y GOLA ELLE
EN ACABADO NEGRO
MATE. ENCIMERA EN GRES
ACABADO EMPERADOR
MATE Y PIEDRA NATURAL
ACABADO BROWN
ANTIQUÉ.





DETTAGLIO COLONNE
CON ANTE BLUNA
IN FINITURA
TECH ALLUMINIO
CHAMPAGNE E PENSILI
BLUNA LEGNO IN
FINITURA ROVERE
CARBONE.

DETAIL OF COLUMNS
WITH BLUNA TECH
DOORS ALUMINIUM
CHAMPAGNE FINISH
AND WALL UNITS
IN BLUNA WOOD
ROVERE CARBONE
FINISH.

DETAIL COLONNES
AVEC FAÇADES
BLUNA EN FINITION
TECH ALUMINIUM
CHAMPAGNE ET
MEUBLES HAUTS BLUNA
BOIS EN FINITION
ROVERE CARBONE.

DETALLES DE
COLUMNAS CON
PUERTAS BLUNA
EN ACABADO TECH
ALUMINIO CHAMPAGNE
Y ALTOS BLUNA
MADERA DE ROVERE
CARBONE.





222

223



DETTAGLIO PIANO
SNACK E BOISERIE LEAF
CON LED INTEGRATI
IN FINITURA LEGNO
ROVERE CARBONE.

DETAIL OF SNACK PLAN
AND LEAF BOISERIE
WITH INTEGRATED
LED IN WOOD ROVERE
CARBONE FINISH.

DETAIL PLAN SNACK
ET BOISERIE LEAF
AVEC LED INTEGRES EN
FINITION BOIS ROVERE
CARBONE.

DETALLE PLAN SNACK
Y BOISERIE LEAF CON
LEDS INTEGRADOS EN
ENCHAPADO DE MADERA
ACABADO ROVERE CARBONE.

DETTAGLIO MADIA
CON ANTE IN
FINITURA BLUNA
TECH ALLUMINIO
CHAMPAGNE E GOLA
ELLE IN FINITURA
NERO OPACO. FIANCHI
IN FINITURA LEGNO
ROVERE CARBONE.
TOP IN FINITURA GRES
EMPERADOR OPACO.

DETAIL OF SIDEBOARD
WITH BLUNA TECH
DOORS ALUMINUM
CHAMPAGNE FINISH
AND ELLE GROOVE IN
MATT BLACK FINISH.
SIDE PANELS IN WOOD
ROVERE CARBONE
FINISH. TOP IN MATT
GRES EMPERADOR
FINISH.

DETAIL BUFFET
AVEC FAÇADES EN
FINITION BLUNA
TECH ALUMINIUM
CHAMPAGNE ET GORGE
ELLE EN FINITION NOIR
MAT. COTES DE FINITION
INTEGRES BOIS ROVERE
CARBONE. PLAN DE
TRAVAIL EN FINITION
GRES EMPERADOR MAT.

DETALLE APARADOR CON
PUERTAS DE ACABADO
BLUNA TECH ALLUMINIO
CHAMPAGNE Y GOLA
ELLE EN ACABADO
NEGRO MATE. COSTADOS
ENCHAPADOS DE MADERA
ACABADO ROVERE
CARBONE. ENCIMERA
EN GRES ACABADO
EMPERADOR OPACO.

224

225







DETTAGLIO PARETE LIVING CON BASI IN FINITURA TECH ALLUMINIO CHAMPAGNE, PENSILI CON ANTE VETRO REFLEX COSTITUITO DA TELAIO IN ALLUMINIO NERO E VETRO FUMÈ, SCHIENALI E COLONNE IN LEGNO FINITURA ROVERE CARBONE.

DETAIL OF BASE UNITS IN TECH ALLUMINIO CHAMPAGNE FINISH AND WALL UNITS WITH REFLEX GLASS DOORS MADE IN BLACK ALUMINIUM FRAME AND FUMÈ GLASS, BACK PANELS AND COLUMNS ARE IN WOOD ROVERE CARBONE FINISH.

DETAIL MUR LIVING AVEC MEUBLES BAS EN FINITION TECH ALUMINIUM CHAMPAGNE, MEUBLES HAUTS AVEC FAÇADES EN VERRE REFLEX COMPOSE PAR UN CADRE EN ALUMINIUM NOIR ET VERRE FUME, DOS ET COLONNES EN BOIS FINITION ROVERE CARBONE.

DETALLE PARED LIVING CON BAJOS EN ACABADO TECH ALLUMINIO CHAMPAGNE, ALTOS CON PUERTAS DE VIDRIO REFLEX MARCO EN ACABADO DE ALUMINIO NEGRO Y VIDRIO FUME', ESPALDA Y COLUMNAS ENCHAPADO DE MADERA ACABADO ROVERE CARBONE.



1

COLONNE COLUMNS COLONNES COLUMNAS

BLUNA TECH ALLUMINIO CHAMPAGNE CON APERTURA GOLA VERTICALE, CASSETTI E BOISERIE LEAF BLUNA LEGNO ROVERE CARBONE. STRUTTURA INTERNA IN FINITURA NERO CARBONE

2

PENSILI WALL UNITS MEUBLES HAUT MUEBLES ALTOS

BLUNA LEGNO ROVERE CARBONE. STRUTTURA INTERNA IN FINITURA NERO CARBONE

3

BASI BASE UNITS MEUBLES BAS MUEBLES BAJOS

BLUNA LEGNO ROVERE CARBONE CON APERTURA GOLA ELLE NERO TRAFFICO OPACO. WORKTOP GRES EMPERADOR OPACO E PIETRA NATURALE BROWN ANTIQUE SPAZZOLATO. PIANO SNACK E BOISERIE LEAF LEGNO ROVERE CARBONE. STRUTTURA INTERNA NERO CARBONE

4

MADIA SIDEBOARD BUFFET PATILLA

BLUNA TECH ALLUMINIO CHAMPAGNE CON APERTURA CON GOLA ELLE NERO TRAFFICO OPACO. FIANCHI LEGNO ROVERE CARBONE. PIANO GRES EMPERADOR OPACO. STRUTTURA INTERNA NERO CARBONE

5

SOGGIORNO LIVING WALL MUR DE SÉJOUR MURO DE SALÒN

BLUNA TECH ALLUMINIO CHAMPAGNE CON APERTURA CON GOLA ELLE NERO TRAFFICO OPACO. PIANO GRES EMPERADOR OPACO. FIANCHI, COLONNE E SCHIENALI BLUNA LEGNO ROVERE CARBONE. VETRINE REFLEX VETRO FUMÉ E TELAIO ALLUMINIO NERO. STRUTTURA INTERNA IN BILAMINATO LEGNO ROVERE TERRANERA CON SCHIENA NERO CARBONE.

230

BLUNA TECH

**SCHEDA TECNICA DATA SHEET
FICHE TECHNIQUE FICHA DE DATOS**

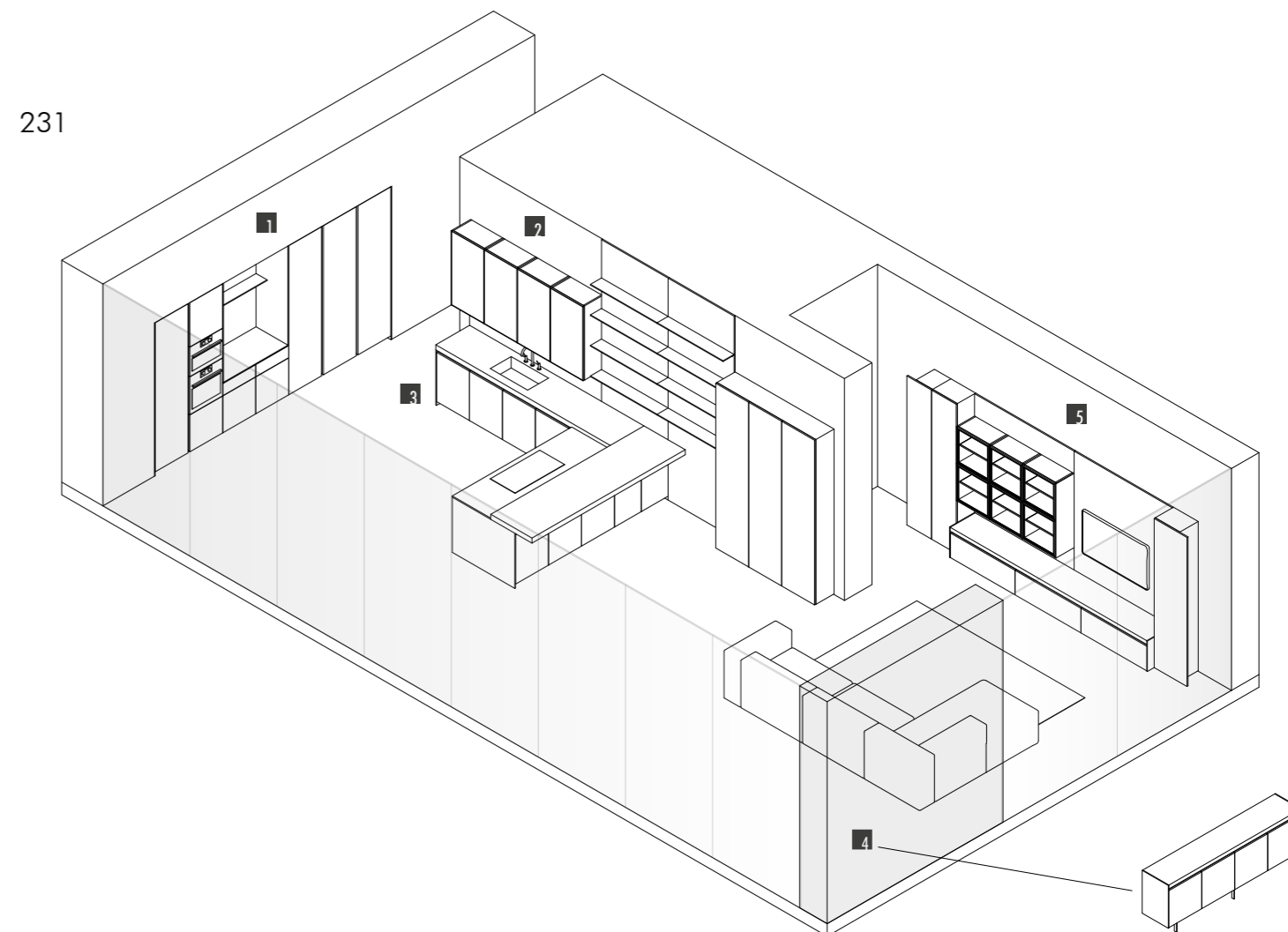

231



BLUNA TECH ALLUMINIO CHAMPAGNE

LEGNO ROVERE CARBONE

GRES EMPERADOR OPACO

PIETRA NATURALE BROWN ANTIQUE SPAZZOLATO

BILAMINATO STRUTTURA NERO CARBONE

VETRO FUMÉ E ALLUMINIO NERO

232

233

FINITURE

FINISHES

TECH OPACO MATT TECH



BIANCO NORDICO OPACO



GRIGIO PIETRA OPACO



GRIGIO ARDESIA OPACO



NERO ONICE OPACO

BLUNA

234

TECH ALLUMINIO ALUMINUM TECH



ALLUMINIO CHAMPAGNE

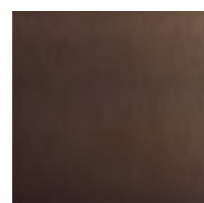

ALLUMINIO BRUNITO

BLUNA

BILAMINATO LEGNO WOOD BILAMINATE



ROVERE OSLO

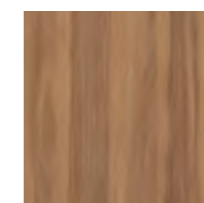

NOCE NATURALE



EUCALIPTO GRIGIO



NOCE MIELE

BLUNA

235



NOCE AMERICANO



ROVERE FUMÉ

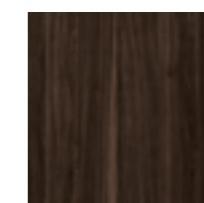

RODIN OLMO



ROVERE BRUCIATO



ROVERE TERRANERA

BILAMINATO MATERICO TEXTURAL BILAMINATE

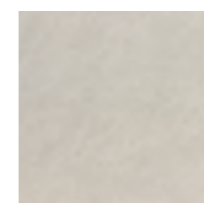

BETON ARGILLA



PIETRA PIASENTINA

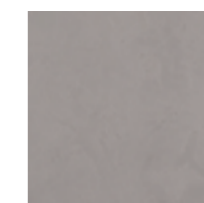

BETON GRIGIO CHIARO



BETON FB02

BLUNA



BRECCIA TORTORA

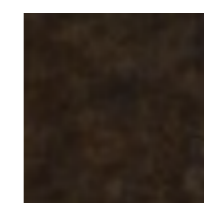

BETON VULCANO



METALLO BRUNITO

LACCATO OPACO MATT LACQUERED

BLUNA SCAVA VOGUE MANTIS

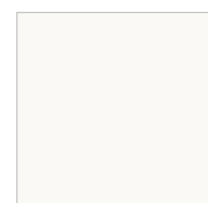

TITAN WHITE OPACO



BIANCO PURO OPACO

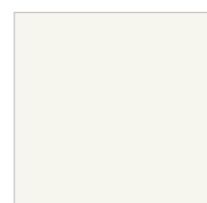

AVORIO OPACO

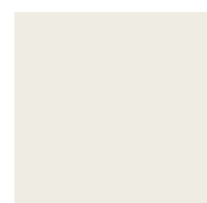

SAHARA BEIGE OPACO

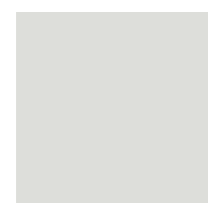

GRIGIO BOX OPACO



GRIGIO FUMO OPACO



BEIGE KENIA OPACO



CAPPUCCINO OPACO



GRIGIO LAVA OPACO



FERRO OPACO



GRIGIO FOSCO OPACO



CARRUBA OPACO



CAFFÈ OPACO



ROSSO TOSCA OPACO



ROSSO VINO OPACO



SALVIA OPACO



VERDE BOSCO OPACO



INK BLUE OPACO



GRIGIO ANTRACITE OPACO



NERO TRAFFICO OPACO



RAL

236

237

LAMINATO FENIX FENIX LAMINATE

BLUNA WORKTOP



BIANCO KOS

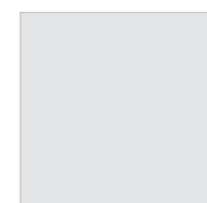

GRIGIO EFESO



CASTORO OTTAWA



GRIGIO LONDRA



VERDE COMODORO



ROSSO JAIPUR



GRIGIO BROMO



NERO INGO

LEGNO WOOD

BLUNA SCAVA VOGUE AVOLA



ROVERE NATURALE
PRECOMPOSTO ALPI



ROVERE MANHATTAN



ROVERE GRIGIO PEPE



ROVERE GRIGIO LONDRA

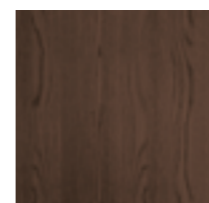

ROVERE TABACCO



ROVERE CARBONE

LEGNO SPECIALE A SPECIAL WOOD A

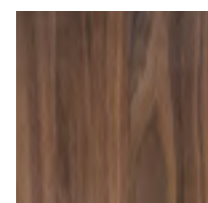

NOCE CANALETTO

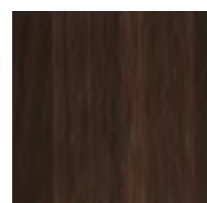

ROVERE TERMOTRATTATO

BLUNA SCAVA VOGUE AVOLA MANTIS

LEGNO SPECIALE B SPECIAL WOOD B



ROVERE VESUVIO DOGA SFALSATA

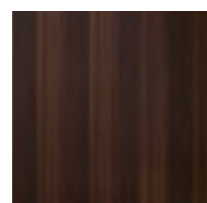

EUCALIPTO SCURO

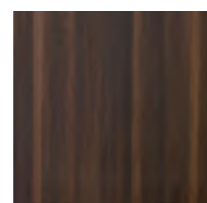

ROVERE MILLERIGHE

BLUNA SCAVA VOGUE AVOLA

238

LEGNO PREMIUM PREMIUM WOOD



OLD ABETE NERO

BLUNA SCAVA

LACCATO LUCIDO GLOSSY LACQUERED



TITAN WHITE LUCIDO



BIANCO PURO LUCIDO



AVORIO LUCIDO



SAHARA BEIGE LUCIDO

BLUNA SCAVA VOGUE



GRIGIO BOX LUCIDO



GRIGIO FUMO LUCIDO



BEIGE KENIA LUCIDO



CAPPUCCINO LUCIDO

239



GRIGIO LAVA LUCIDO



FERRO LUCIDO



GRIGIO FOSCO LUCIDO



CARRUBA LUCIDO



CAFFÈ LUCIDO



ROSSO TOSCA LUCIDO



ROSSO VINO LUCIDO



SALVIA LUCIDO



VERDE BOSCO LUCIDO



INK BLUE LUCIDO



GRIGIO ANTRACITE LUCIDO



NERO TRAFFICO LUCIDO



RAL

LACCATO METAL 4.0 4.0 METAL LACQUERED

BLUNA SCAVA VOGUE MANTIS

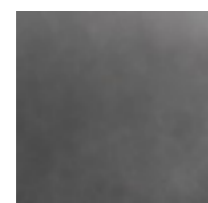

TITANIO

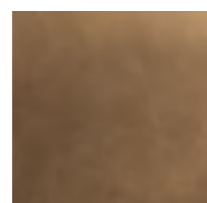

OTTONE

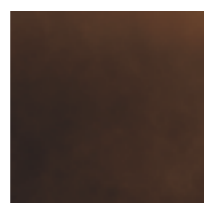

BRONZO

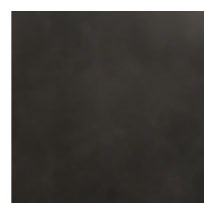

PELTRO

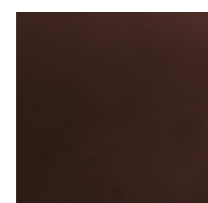

AMARANTO

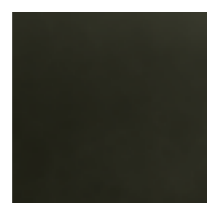

FORESTA

240

LEGNO SPINA DI PESCE HERRINGBONE WOOD

MANTIS

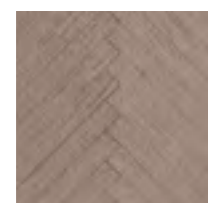

ROVERE SATURNO

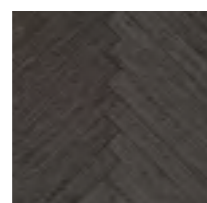

ROVERE CORTECCIA

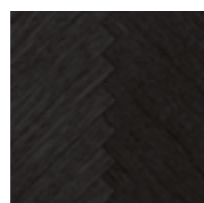

ROVERE MAGMA

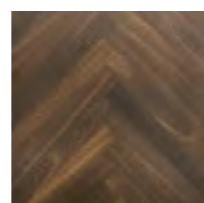

ROVERE TERMOTRATTATO

ACCIAIO STEEL

BLUNA WORKTOP



ACCIAIO SATINATO

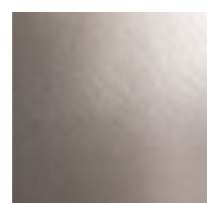

ACCIAIO VINTAGE

RESINA RESIN

BLUNA



LIGHT GREY

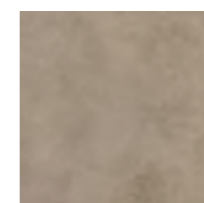

TORTORA



SILVER GREY

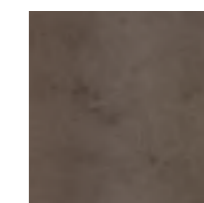

DARK GREY

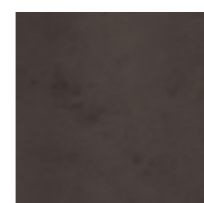

NERO

241

PIETRA NATURALE NATURAL STONE

WORKTOP



BIANCO CARRARA SPAZZOLATO

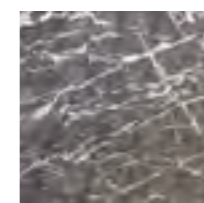

GRIGIO ALPINO SPAZZOLATO

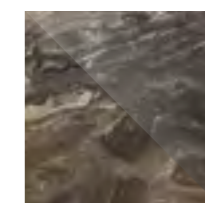

ARABESCATO OROBICO LUCIDO

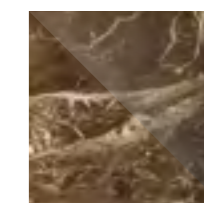

BROWN EMPERADOR LUCIDO

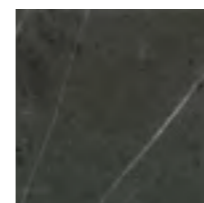

GREY STONE SPAZZOLATO

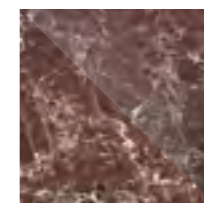

ROSSO LEVANTO LUCIDO



GRANITO NEW CAMBRIAN BLACK SPAZZOLATO

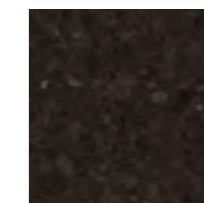

BROWN ANTIQUE SPAZZOLATO

GRES "INSIDE"



PIASENTINA GRIGIO
FIAMMATO

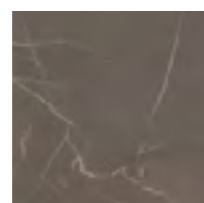

PIASENTINA TAUPE
FIAMMATO

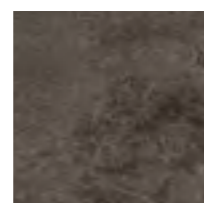

PORFIDO MARRONE
FIAMMATO

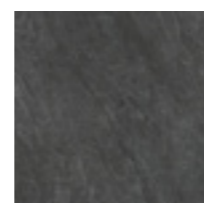

CARDOSO NERO
FIAMMATO

AVOLA WORKTOP

VETRO GLASS



TITAN WHITE OPACO

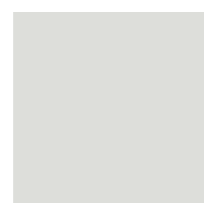

GRIGIO BOX OPACO



BEIGE KENIA OPACO



GRIGIO ANTRACITE OPACO

242



NERO TRAFFICO OPACO



TITAN WHITE LUCIDO



GRIGIO BOX LUCIDO



BEIGE KENIA LUCIDO



GRIGIO ANTRACITE LUCIDO



NERO TRAFFICO LUCIDO



BRONZO OPACO



STOPSOL SPECCHIO
BRONZO



STOPSOL SPECCHIO FUMÈ

LAB AVOLA

GRES

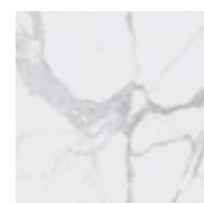

STATUARIO ALTISSIMO
OPACO



BRECCIA CAPRAIA OPACO



FOKOS ROCCIA OPACO



PIETRA DI SAVOIA
GRIGIO OPACO



NERO GRECO OPACO



STATUARIO ALTISSIMO
LUCIDO



TAJ MAHAL OPACO

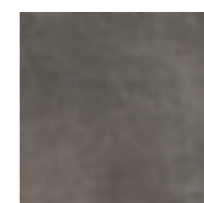

FOKOS PIOMBO OPACO



PIETRA DI SAVOIA
ANTRACITE OPACO

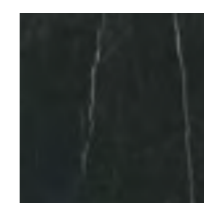

MARBLE MARQUINIA
OPACO



MARBLE WHITE OPACO



FOKOS SALE OPACO



STONE BROWN OPACO

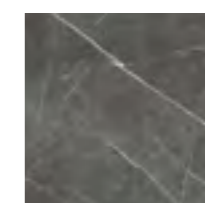

MARBLE GREY OPACO

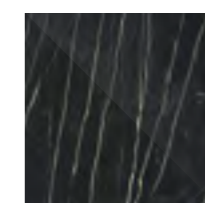

MARBLE LAURENT
LUCIDO



MARBLE CALACATTA
GOLD OPACO

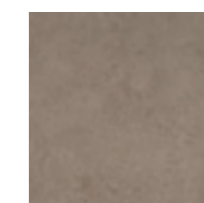

FOKOS TERRA OPACO

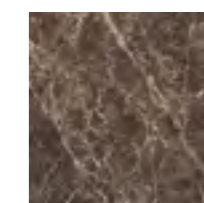

EMPERADOR OPACO

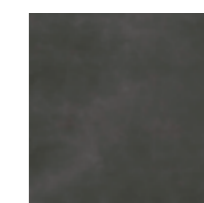

CALCE NERO OPACO

AVOLA WORKTOP

243

QUARZO QUARTZ



AOSTA LUCIDO

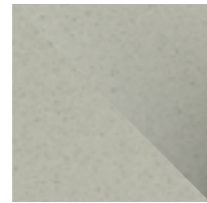

YEMEN LUCIDO

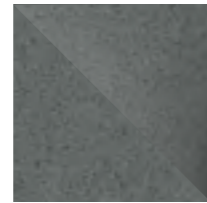

CARNIA LUCIDO

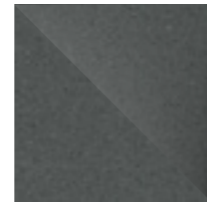

CALEDONIA LUCIDO



CITY BEIGE OPACO

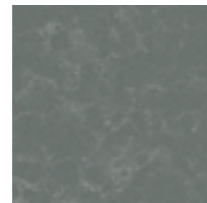

CITY GREY OPACO



ARDENNE OPACO



VEGA LUCIDO



VERMONT OPACO

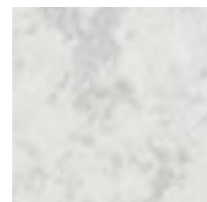

METROPOLIS OYSTER OPACO



METROPOLIS STEEL OPACO

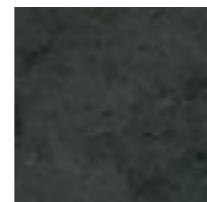

METROPOLIS GALAXY OPACO

WORKTOP

244

245

LAMINATO LAMINATE

WORKTOP



BIANCO LUNA OPACO

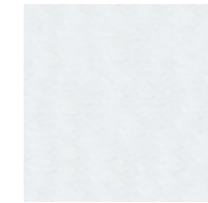

BIANCO PLAMKY

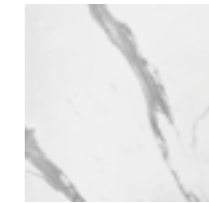

STATUARIO VENATO



BETON FB02



MAILAND PLAMKY



WRAKY STONE OF NANTO



PIETRA FUMO



PORFIDO GRIGIO MIKA



CUMA LIGHT



SILVER CHIARO



PIETRA GRIGIA



CUMA DARK



PIETRA ANTRACITE



GRIGIO MARE OPACO



CHERRY LITE



VISONE OPACO



PLAMKY WEAVE BROWN

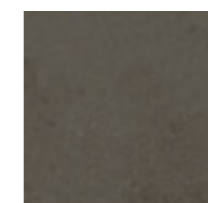

PORFIDO NATURALE MIKA

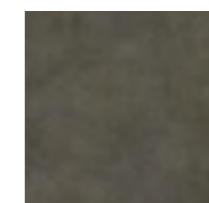

SILVER SCURO

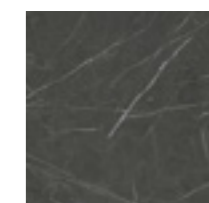

TERRA STONE

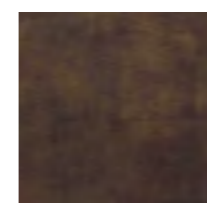

BRONZO



ORIENTAL

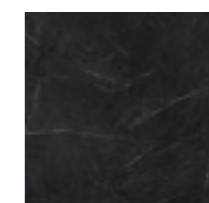

PIETRA NERA

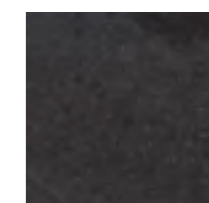

PORFIDO NERO MIKA

HPL

AVOLA WORKTOP

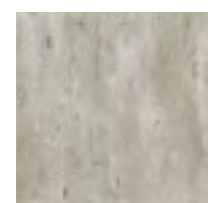

REZINA CLIMB

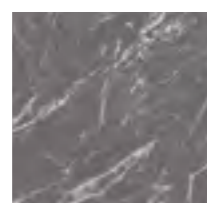

ALICANTE CLIMB



CEMENTO CLIMB

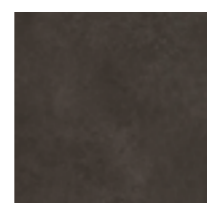

VULCANO CLIMB

ART DIRECTION

RICERCA E SVILUPPO BINOVA

GRAPHIC DESIGN

RICERCA E SVILUPPO BINOVA

COPY

RICERCA E SVILUPPO BINOVA

RENDER

MATIC ANIMATION

COLOR SEPARATION

SINCROMIA

PRINT

SINCROMIA



Binova

è un marchio Cubo Design S.r.l.

Località Case Sciarroni - Grasciano
I-64024 Notaresco - Teramo (TE) - Italy
info@cubodesign.it
www.binova.it

Cubo design S.r.l. nel perseguire una politica volta al costante miglioramento, si riserva il diritto di apportare, in qualsiasi momento e senza preavviso, le modifiche ai prodotti che riterrà utili e necessarie. L'effettiva disponibilità di quanto a catalogo deve essere verificata al momento dell'ordine. A causa di naturali limiti tecnici di riproduzione e stampa, il colore dei modelli a catalogo è puramente indicativo e non può costituire motivo di rivalsa. Cubo design S.r.l. declina ogni responsabilità per difetti e malfunzionamenti di elettrodomestici ed apparecchiature: eventuali contestazioni dovranno essere rivolte direttamente al produttore ed ai loro centri di assistenza. In order to constantly improve its products, Cubo design S.r.l. reserves the right to modify its products as it sees fit, without prior notification. The effective availability of the articles in the catalogue, must be actually checked out at the time of the order. Because of natural technical limits of the method of reproduction and printing, the colour of the models in the catalogue is purely indicative and cannot be claimed as reason for compensation and legal action. Cubo design S.r.l. every liability for defects and malfunctioning of appliances and pieces of equipment: eventual claims will have to be addressed directly to the producers and their assistance centres.